

EagleBurgmann BP Seals

The EagleBurgmann BP Seal is a revolutionary, patent-pending sealing solution that provides maximum protection against contaminants while maintaining lubrication in the bearing. The seal's innovative design enables bearing protection that is more durable and reliable than any other competing product on the market today.

What Makes EagleBurgmann's BP Seal Better

Two Vertical Internal Chambers – The BP Seal utilizes the laws of physics with the vertical alignment of the internal chambers to create the most effective and efficient bearing protection device on the market today.

Internal Static Elastomers – BP Seal is the only true non-contacting device with two internal static elastomers, eliminating the potential of dynamic O-ring hang up.

Contaminant Exclusion – With double exclusion chambers, the BP Seal can exclude higher volumes of contaminant, ensuring longer bearing life.

Angled Oil Return – With an angled oil return, the BP Seal offers enhanced return flow and higher volume capacity with no oil leakage.

Angled Interface – While competing products offer a straight interface, the BP Seal features an angled interface, giving the contaminant direction and flow to expel more efficiently.

Common Applications

- Centrifugal pumps
- Steam turbines
- Motors
- Gearboxes
- Mixers
- Blowers/fans
- Pillow block bearings

Standard Materials

- Stainless Rotor
- Bronze Stator
- Viton® Elastomers
- All Other Material Combinations Available

Features

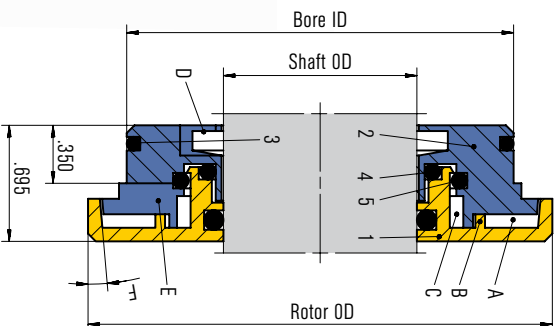

Item	Description
1	Rotor
2	Stator
3	Stator O-Ring (optional)
4	Coalescing ring
5	Unitizing/coalescing ring
A	First contaminant collection chamber
B	Integral internal finger
C	Second contaminant collection chamber
D	Angled oil drainback
E	Contamination exclusion slot
F	Angled stator/rotor interface



Argentina · Australia · Austria · Belarus · Belgium · Bulgaria · Brazil · Canada · Chile · China · Columbia · Cyprus · Czech Republic · Denmark · Ecuador · Egypt · Estonia · Finland · France · Germany · Great Britain · Greece · Hungary · India · Indonesia · Iraq · Israel · Italy · Japan · Jordan · Kazakhstan · Korea · Kuwait · Latvia · Lithuania · Malaysia · Mauritius · Mexico · Morocco · Myanmar · Netherlands · New Zealand · Nigeria · Norway · Oman · Pakistan · Paraguay · Peru · Philippines · Poland · Qatar · Romania · Russia · Saudi Arabia · Singapore · Slovenia · Slovak Republic · South Africa · Spain · Sweden · Switzerland · Syria · Taiwan · Thailand · Trinidad and Tobago · Tunisia · Turkey · Turkmenistan · Ukraine · United Arab Emirates · Uruguay · USA · Uzbekistan · Venezuela · Vietnam · www.eagleburgmann.com/world



1m/04.14

EagleBurgmann is one of the internationally leading companies for industrial sealing technology. Our products are used everywhere where safety and reliability are important: in the oil and gas industry, refining technology, the petrochemical, chemical and pharmaceutical industries, food processing, power, water, mining, pulp & paper, aerospace and many other spheres. Every day, more than 6,000 employees contribute their ideas, solutions and commitment towards ensuring that customers all over the world can rely on our seals. Our modular TotalSealCare service underlines our strong customer orientation and offers tailor-made services for every application.

eagleburgmann.com
info@eagleburgmann.com

EagleBurgmann®
 Rely on excellence

EagleBurgmann®
 Rely on excellence

BP Seal
 Maximum Bearing Protection

