

Seal supply systems

Thermosiphon systems



Loop systems



Heat exchangers



Gas supply systems





Content and other brochures

Seal supply systems

Index 5

EagleBurgmann – Your System Supplier

Separately available brochures offer information about additional product lines as well as notes on the technology and selection of mechanical seals.

All products can be retrieved interactively from eagleburgmann.com. Among others, you will find current data sheets in PDF format available for download here.

Mechanical seal technology and selection

Brochure 58 pages (Code: DMS_TSE)

Technical principles, designation codes, API plans, notes on installation and operation and articles covering theory and practice are summarized in the first part. The second part concerns choosing a seal according to media. Recommendations for arrangement, operation, type and materials of the required mechanical seal for over 900 media. With extensive additional information.

Mechanical seals, Magnetic couplings

Catalog 146 pages (Code: DMS_MSE)

The complete range of seals from EagleBurgmann:

Pump seals, agitator seals, compressor seals, and magnetic couplings.

Carbon floating ring seals

Brochure 32 Pages (Code: EBES)

Maintenance-free, compact cartridge labyrinth seals with long service life and best performance from EagleBurgmann-Espey. For the sealing of gases, dust and vapors in turbines, fans, compressors, centrifuges and mills.

Additional Information

TotalSealCare 80
Company profile 2
Additional product lines 76

Important note

All the technical specifications are based on extensive tests and our many years of experience. However, the diversity of possible applications means that they can serve as guide values only.

It should be noted that the extremal values of each operating parameter cannot be applied at the same time because of their interaction. Furthermore, the operating range of each specific product depends on the respective shaft diameter, materials used, mode of operation and on the medium to be sealed.

A guarantee can only be given in the individual case if the exact conditions of application are known and these are confirmed in a special agreement. When critical conditions of operation are involved, we recommend consulting with our specialist engineers.

Subject to change.

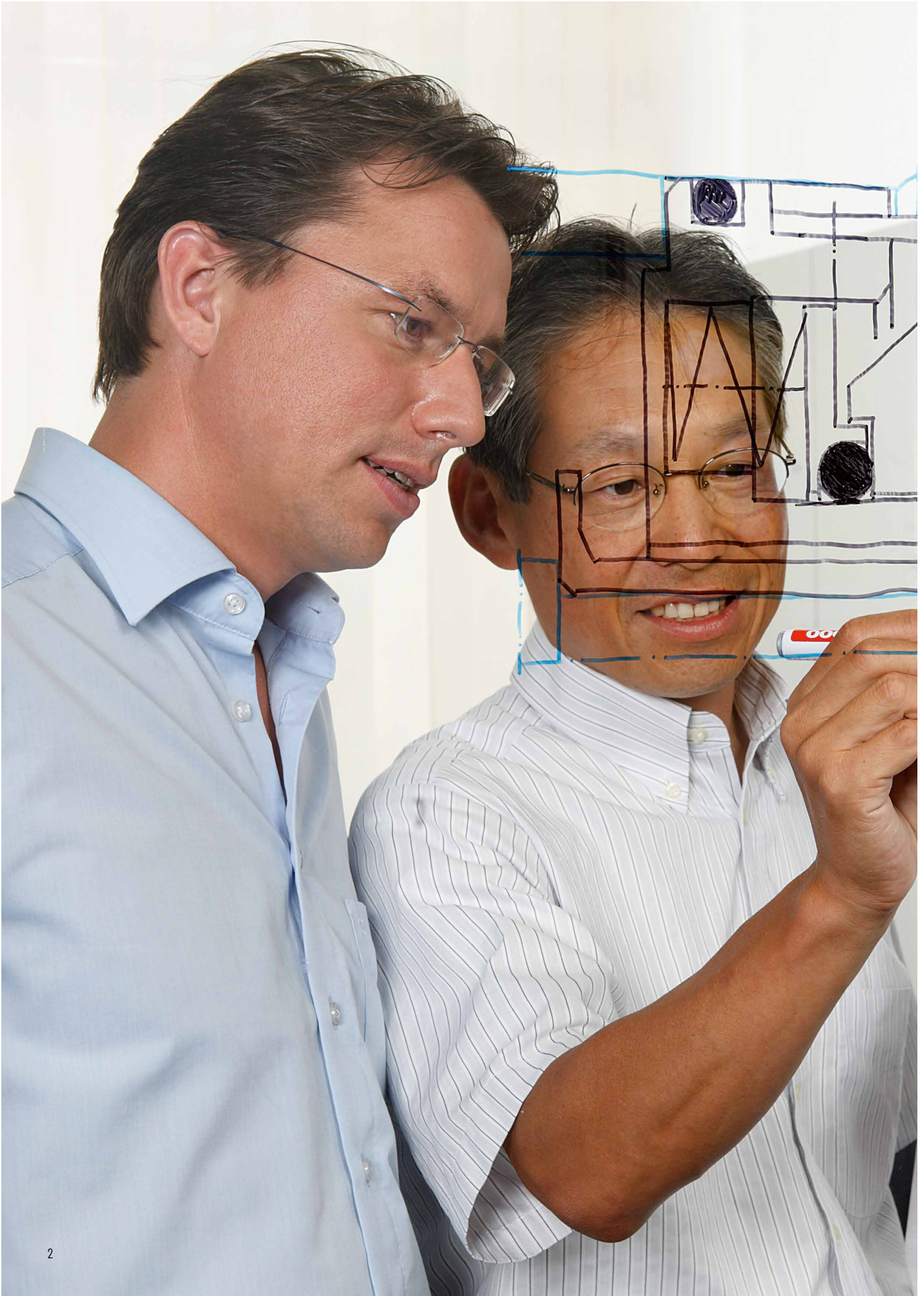



Our products – as varied as our customers

EagleBurgmann products deliver safe, reliable sealing performance in any application including oil pumping and cracking, gas compression, process gas containment, phase separation or synthesis of chemical substances, pipeline sealing, dairy product filling or compensation of temperature expansion in flue gas systems.

Our challenge is to design seals that are able to withstand a wide range of media, different aggregate states and varying pressure and temperature and to provide special solutions for small installation up to seal contact areas of several meters. Every application has its own special requirements profile, and our job is to provide the best sealing solution.

The EagleBurgmann portfolio: A product range with an unlimited horizon.

EagleBurgmann is one of the world's leading manufacturer of industrial sealing solutions. Our extensive portfolio includes everything from standard seals to one-off application-specific designs:

- Mechanical seals
- Magnetic couplings
- Seal supply systems
- Carbon floating ring seals
- Compression packings
- Gaskets
- Expansion joints
- Special products
- TotalSealCare Services

Total commitment to quality excellence.

Outstanding quality is the top priority at EagleBurgmann. Our products are designed for user-friendly installation, optimal functionality and long service life. Our R&D activities, advanced quality management system, in-house test facilities and in-depth engineering expertise ensure that our seals meet the most demanding customer expectations. Starting right back in the development phase, our employees continually verify the quality of our products, and we carry out systematic inspection and testing to guarantee that customers are getting top quality.

Proud of the trust which our customers place in us.

EagleBurgmann is a dependable, competent partner. Our customers are always in total control of the media in their pumps, agitators, compressors, blowers, turbines, valves and pipeline systems even when operating conditions are extremely harsh. There is good reason why customers in the oil & gas, refinery, chemical, energy, food processing, paper, water, marine, aerospace, mining and other industries choose EagleBurgmann as their sealing solutions supplier.



Sperrdruck
Seal pressure
Pression de barrage



gmann®

4

Herstelljahr

Seal supply systems

Depending on the design, application and mode of operation, supply systems are needed to flush, cool and pressurize mechanical seals and magnetic couplings and provide leakage compensation. EagleBurgmann supplies a complete range of solutions from a single source including design, production, commissioning and service. The portfolio includes a complete line of API compliant supply systems.

We also offer a complete range of seal supply systems and components acc. to API 682 4th edition. Request our separately available API 682 printed publication series. Additional comprehensive documents and information are available at eagleburgmann.com/api682.

Quench systems

QFT1000	6
QFT2000	8
QFT3000	10
QFT6000	12

Thermosiphon systems

TS1000	14
TS2000	16
TS3000	18
TS3016	19
TS4000	20
TS5000	22
TS6000 / TSA6 / TSB6	24

Closed loop systems

SPO / SPB6 (Plan 53B)	26
SPO / SPC6 (Plan 53C)	28

Pressure booster systems

DRU2000	30
---------------	----

Barrier fluid systems

SPA	32
-----------	----

Components

DHE Pressure accumulator unit	34
DRE Pressure control unit	35
VTE Distribution unit	36

Refill units

SPN Automatic	38
SPN Manuel	40

Heat exchangers

WDK	41
WED	42
WEF6	44
WE	45
WEL1000	46
WEL2000 / WEL6	47

Leakage control systems

SPX6 (Plan 32)	48
LS050 / LSA6 / LSB6 (Plan 65)	49
SPP6 (Plan 66A, 66B)	50
LS050 / LSC6 (Plan 75)	51
SPP6 (Plan 76)	52

External flush systems

FLC200	53
BestFlow	54

Pumps

SPU Circulations pumps	55
HPS Screw pumps	56

Cyclone separators, filters

ZY Cyclone separator	58
MAF2001 Magnetic filter	60
MAF203 Magnetic filter	61
MAA Magnetic separator	62

Instrumentation

SP23 Flowmeter	63
SP23 Pressure gauge	64
SP23 Thermometer	65
SPI Measuring unit	66
SPL Level indicator	67
SPK Contact unit	68
SPS Level switch	69

Gas supply systems

GSS	70
RoTechBooster	72
SMS Seal Management System	74

QFT1000

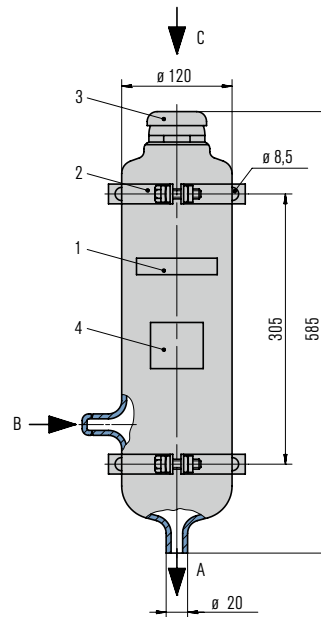

Features

Quench fluid supply systems are used to supply single or tandem mechanical seals. They act as a convenient fluid reservoir. The exchange of fluid takes place by the thermosiphon principle or by forced circulation, e.g. with a pumping screw. The QFT1000 is made of transparent polyethylene, complete with clips made of stainless steel. The QFT1000 is resistant to water, glycerine, glycols and methanol; not resistant to mineral oils and toluene.

Seal supply in accordance with API 682/ISO 21049: Plan 51.

Advantages

- Excellent value for money
- Transparent polyethylene: fluid level is read off directly on the quench fluid tank
- Resistant to a wide range of quench media Quickly and easily installed
- Combined filling and ventilation filter in the quench fluid tank for reliable operation

Functional description

Quench fluid systems are employed:

- to absorb leakage
- to monitor the leakage rate (e.g. through periodic reading of the level in the tank)
- to lubricate and to cool the outboard mechanical seal in a tandem arrangement
- to prevent icing
- to protect against dry running
- to stabilize the lubricating film
- to exclude air from the media in order to prevent a reaction with oxygen in the air

Item Description

- | Item | Description |
|------|------------------------------|
| 1 | Storage tank (capacity 4 l) |
| 2 | Clip |
| 3 | Inlet filter with vented cap |
| 4 | Name plate |

Recommended applications

- Chemical industry
- Food and beverage industry
- Pharmaceutical industry

Product variants

QFT1000/M001-00

Version with threaded coupling for connecting a tube dia. 10 mm.

Connections

- | | |
|---|---------------------------------|
| A | To mechanical seal |
| B | From mechanical seal (optional) |
| C | Filling |

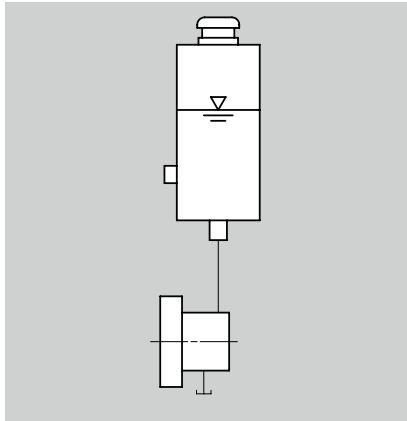

Dead-end quench (Plan 51): Quench fluid from an elevated tank. The characteristic feature of this principle is that no heat is dissipated by the system.

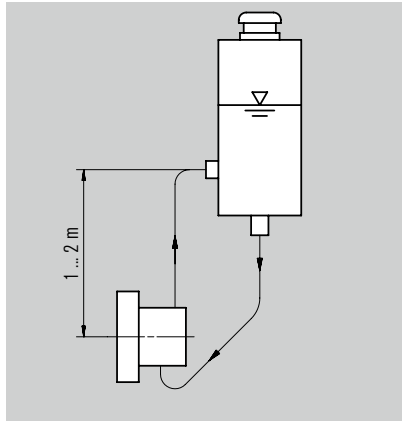

Circulation: Quench fluid from an elevated tank; external tank, pressureless; thermosiphon or forced circulation. In this case heat is dissipated by the circulation. Cooling capacity by convection is minimal, however.

Install the quench fluid tank approx. 1 ... 2 m (3.3 ... 6.6 ft) above the mechanical seal. Install connection pipes To mechanical seal with low flow resistance. Pipes must vent automatically in the direction of the tank. It is imperative that air pockets are prevented. The minimum filling level must always be above the connection socket at the side (in the case of the thermosiphon principle). Quench fluid systems can be operated in two different modes.

Designation	QFT1000-00	QFT1000/M001-00
Volume (liters)	4	4
Allowable pressure	Pressureless	Pressureless
Allowable temperature	-30 °C ... +70 °C (-22 °F ... +158 °F)	-30 °C ... +70 °C (-22 °F ... +158 °F)
Material, tank		
Polyethylene	■	■
Material, filling filter		
Polyamide	■	■
Process connections		
Hose	■	
Fitting for tube, 10 mm		■

Other versions on request.

QFT2000

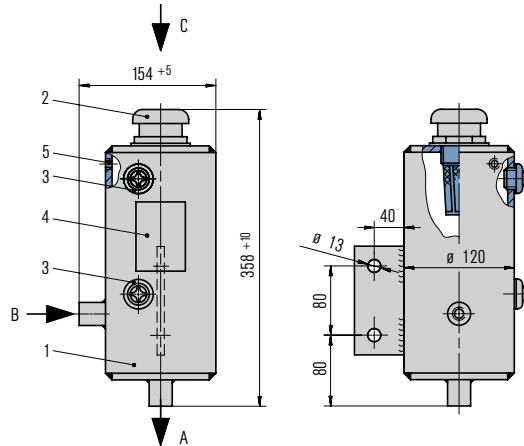

Features

Quench fluid supply systems are used to supply single or tandem mechanical seals. They act as a convenient fluid reservoir. The exchange of fluid takes place by the thermosiphon principle or by forced circulation, e.g. with a pumping screw. The QFT2000 stainless steel tank is equipped with sight-glasses for monitoring the MIN/MAX level and can be fastened with a lug fixture. The leakage overflow can be selectively discharged.

Seal supply in accordance with API 682/ISO 21 049: Plan 51.

Advantages

- Available in a range of different material combinations: suitable for a wide range of demanding operating conditions
- Design for medium temperatures of up to +200 °C (+392 °F)
- Tank made of 1.4571: high resistance to corrosive media
- Integrated overflow for selective discharge of leakage
- Instead of the sight-glass it is possible to use a level switch to monitor the fluid volume
- Combined filling and ventilation filter in the quench fluid tank for reliable operation

Functional description

Quench fluid systems are employed:

- to absorb leakage
- to monitor the leakage rate (e.g. through periodic reading of the level in the tank)
- to lubricate and to cool the outboard mechanical seal in a tandem arrangement
- to prevent icing
- to protect against dry running
- to stabilize the lubricating film
- to exclude air from the media in order to prevent a reaction with oxygen in the air

Item Description

- | Item | Description |
|------|------------------------------|
| 1 | Storage tank (capacity 3 l) |
| 2 | Inlet filter with vented cap |
| 3 | Sight-glass or level switch |
| 4 | Name plate |
| 5 | Overflow G1/8" |

Connections

- | | |
|---|----------------------|
| A | To mechanical seal |
| B | From mechanical seal |
| C | Filling |

Recommended applications

- Chemical industry
- Food and beverage industry
- Pharmaceutical industry

Product variants

Instead of the inspection glass, a level switch can be used for monitoring the fluid volume:

- MIN level: SPS2000/A051-00
- MAX level: SPS2000/A052-00
- MIN/MAX level: SPS2000/A053-00

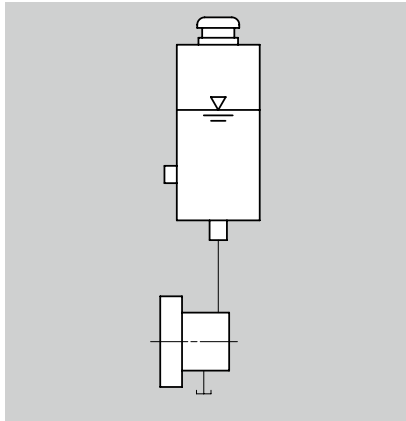

Dead-end quench (Plan 51): Quench fluid from an elevated tank. The characteristic feature of this principle is that no heat is dissipated by the system.

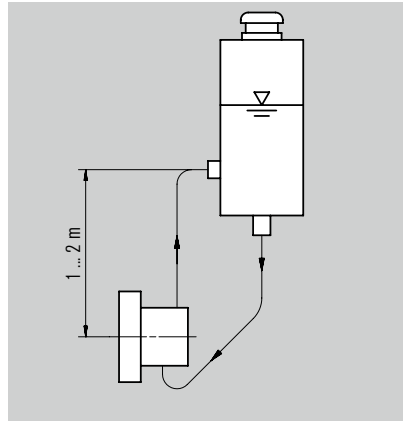

Circulation: Quench fluid from an elevated tank; external tank, pressureless; thermosiphon or forced circulation. In this case heat is dissipated by the circulation. Cooling capacity by convection is minimal, however.

Install the quench fluid tank approx. 1 ... 2 m (3.3 ... 6.6 ft) above the mechanical seal. Install connection pipes To mechanical seal with low flow resistance. Pipes must vent automatically in the direction of the tank. It is imperative that air pockets are prevented. The minimum filling level must always be above the connection socket at the side (in the case of the thermosiphon principle). Quench fluid systems can be operated in two different modes.

Designation	QFT2000-00	QFT2000/A001	QFT2000/A002	QFT2000/A500	QFT2000/A501	QFT2000/A502
Standard version	■		■			
Volume (liters)	3	3	3	3	3	3
Allowable pressure	Pressureless	Pressureless	Pressureless	Pressureless	Pressureless	Pressureless
Allowable temperature	-30 °C ... +70 °C (-22 °F ... +158 °F)	-30 °C ... +120 °C (-22 °F ... +248 °F)	-30 °C ... +200 °C (-22 °F ... +392 °F)	-30 °C ... +70 °C (-22 °F ... +158 °F)	-30 °C ... +120 °C (-22 °F ... +248 °F)	-30 °C ... +200 °C (-22 °F ... +392 °F)
Material, tank						
1.4571	■	■	■	■	■	■
Material, filling filter						
Polyamide	■	■		■	■	
1.4571			■			■
Material, inspection glass						
Acryl/NBR	■			■		
Borosilicate/PTFE		■	■		■	■
Process connections						
G 1/2"	■	■	■			
1/2 NPT				■	■	■

Other versions on request.

QFT3000

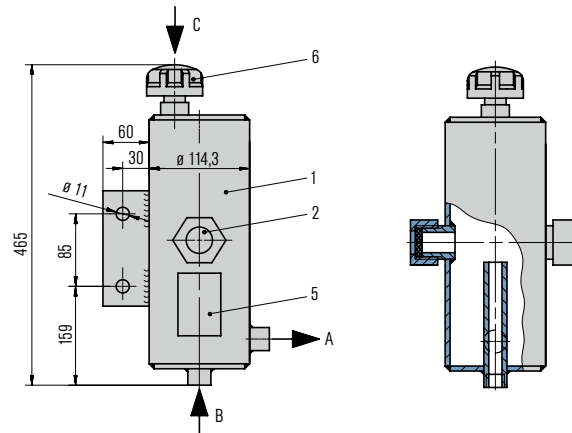

Features

Quench fluid supply systems are used to supply single or tandem mechanical seals. They act as a convenient fluid reservoir. The exchange of fluid takes place by the thermosiphon principle or by forced circulation, e.g. with a pumping screw. The QFT3000 stainless steel tank is equipped with a sight-glass for monitoring the MIN filling level and can be fastened with a lug fixture.

Seal supply in accordance with API 682/ISO 21 049: Plan 51.

Advantages

- Two sight-glasses fitted on opposite sides enable optimum reading of the fluid level and condition of the medium
- Tank made of 1.4571: high resistance to corrosive media
- Return flow via integrated rising pipe for selective current control
- Combined filling and ventilation filter in the quench fluid tank for reliable operation

Functional description

Quench fluid systems are employed:

- to absorb leakage
- to monitor the leakage rate (e.g. through periodic reading of the level in the tank)
- to lubricate and to cool the outboard mechanical seal in a tandem arrangement
- to prevent icing
- to protect against dry running
- to stabilize the lubricating film
- to exclude air from the media in order to prevent a reaction with oxygen in the air

Item Description

- | Item | Description |
|------|-----------------------------|
| 1 | Storage tank (capacity 3 l) |
| 2 | Sight-glass |
| 5 | Name plate |
| 6 | Filter and breather |

Connections

- | | |
|---|----------------------|
| A | To mechanical seal |
| B | From mechanical seal |
| C | Filling |

Recommended applications

- Chemical industry
- Food and beverage industry
- Pharmaceutical industry

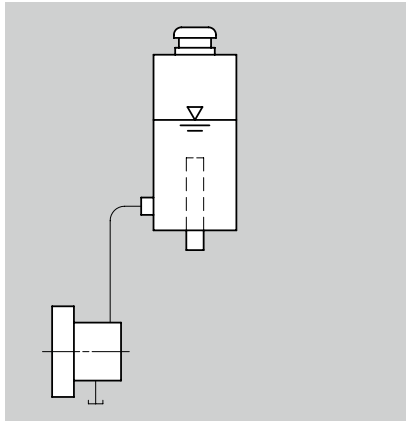

Dead-end quench (Plan 51): Quench fluid from an elevated tank. The characteristic feature of this principle is that no heat is dissipated by the system.

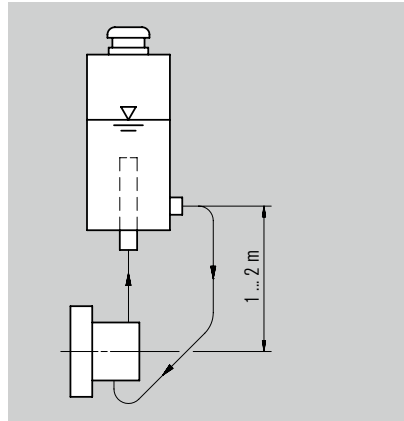

Circulation: Quench fluid from an elevated tank; external tank, pressureless; thermosiphon or forced circulation. In this case heat is dissipated by the circulation. Cooling capacity by convection is minimal, however.

Install the quench fluid tank approx. 1 ... 2 m (3.3 ... 6.6 ft) above the mechanical seal. Install connection pipes To mechanical seal with low flow resistance. Pipes must vent automatically in the direction of the tank. It is imperative that air pockets are prevented. The minimum filling level must always be above the connection socket at the side (in the case of the thermosiphon principle). Quench fluid systems can be operated in two different modes.

Designation	QFT3000/M001	QFT3000-00
Standard version	■	■
Volume (liters)	3	3
Allowable pressure	Pressureless	Pressureless
Allowable temperature	-40 °C ... +120 °C (-40 °F ... +248 °F)	-40 °C ... +120 °C (-40 °F ... +248 °F)
Material, tank	■	■
1.4571	■	■
Material, filling filter	■	■
Glass-fibre-reinforced polyamide	■	■
Material, inspection glass	■	■
Borosilicate/PTFE	■	■
Process connections	■	■
G 1/2"	■	■

Other versions on request.

QFT6000

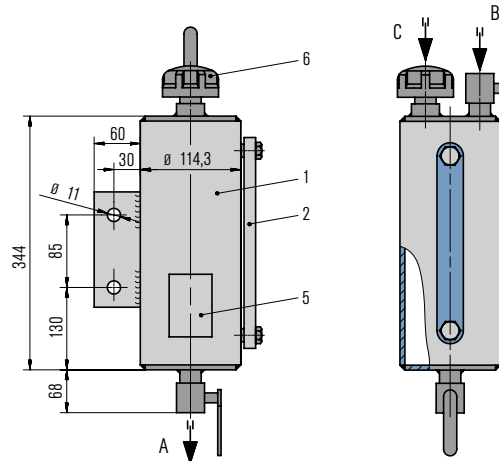

Features

Quench fluid supply systems are used to supply single mechanical seals. They act as a convenient fluid reservoir. The QFT6000 stainless steel tank is equipped with a sight-glass for monitoring the MIN/MAX filling level and can be fastened with a lug fixture.

Circulation in accordance with API 682/ISO 21 049: Plan 51.

Advantages

- Sight-glass for MIN/MAX monitoring has a large indicator area
- Filling is possible via a filling filter or a separate pipe connection
- Combined filling and ventilation filter in the quench fluid tank for reliable operation
- Tank made of 1.4571: high resistance to corrosive media

Functional description

- Quench fluid systems (Plan 51) are employed:
- to absorb leakage
 - to monitor the leakage rate (e. g. through periodic reading of the level in the tank)
 - to prevent icing
 - to protect against dry running
 - to stabilize the lubricating film
 - to exclude air from the media in order to prevent a reaction with oxygen in the air

Item Description

- | Item | Description |
|------|-----------------------------|
| 1 | Storage tank (capacity 3 l) |
| 2 | Sight-glass |
| 5 | Name plate |
| 6 | Filter and breather |

Connections

- | | |
|---|-----------------------------|
| A | To mechanical seal |
| B | Filling via pipe connection |
| C | Filling via filling filter |

Recommended applications

- Refining technology
- Oil and gas industry
- Chemical industry
- Petrochemical industry

Product variant

QFT6000A4M001-D0

Quench system according to API 682, 4th edition.



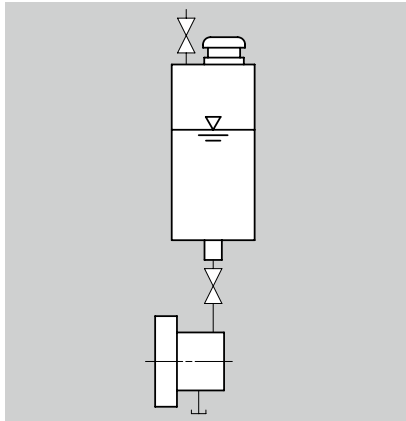

Install the quench fluid tank above the mechanical seal. Install connection pipes To mechanical seal with low flow resistance. Pipes must vent automatically in the direction of the tank. It is imperative that air pockets are prevented.

The QFT6000 quench fluid system can be operated in accordance with Plan 51 (dead-end quench). Quench fluid from elevated tank. The characteristic feature of this principle is that no heat is dissipated by the system.

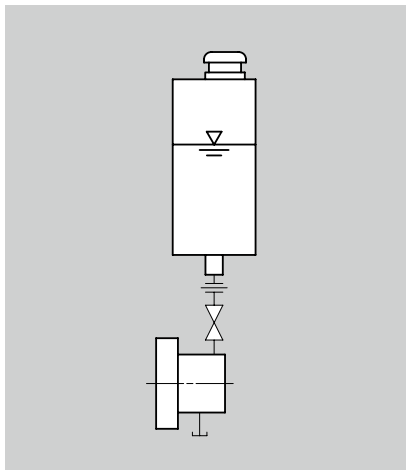

P&ID for QFT6 quench system according to API 682 4th edition.

Designation	QFT6000/M001-DO	QFT6000A4M001-DO
Volume (liters)	3	3
Allowable pressure	Pressureless	Pressureless
Allowable temperature	-20 °C ... +80 °C (-4 °F ... +176 °F)	-20 °C ... +100 °C (-4 °F ... +212 °F)
Material, tank		
1.4571	■	■
Material, filling filter		
Glass-fibre-reinforced polyamide	■	■
Material, inspection glass		
Glass/FKM	■	
Borosilicate / PTFE		■
Process connections		
1/2" NPT (t)	■	■
Execution		
API 682 3rd Edition	■	
API 682 4th Edition		■

TS1000



Features

With the EagleBurgmann TS1016 thermosiphon system it is possible to supply buffer/barrier fluid to double and tandem mechanical seals for a broad range of applications. The TS1016 thermosiphon vessel is available in 2 standard sizes with flat ends, sight-glasses for level monitoring and with or without cooling coil. TS vessels are equipped as standard with all the necessary system connections and brackets. The modular system allows the TS1016 vessels to be combined with a wide range of system components such as, level switch, circulation pump, hand refill pump, thermometer, base frame, etc.

Circulation in accordance with API 682/ISO 21 049: Plan 52, Plan 53A

Advantages

- Available in 2 standard sizes
- Modular system: combination with a wide range of system components possible
- Vessel made of 1.4571 stainless steel/borosilicate
- sight-glasses: suitable for universal applications
- All system connections on the face sides
- Available with or without cooling coil
- Low space requirements because of compact design

Functional description

The TS system performs all the basic functions of a buffer/barrier system for the operation of double seals:

- to pressurize the buffer chamber
- leakage compensation
- buffer/barrier fluid is circulated by thermosiphon effect or forced circulation system
- to cool the seal
- to selectively absorb product leakage and prevent dry running (tandem arrangement)

Use compressed air or nitrogen for pressurization.

Standards and approvals

- PED 97/23 EC (Design and production in accordance with EU Pressure Equipment Directive)
- SELO, GOST on request

Recommended applications

- Chemical industry
- Petrochemical industry
- Pulp and paper industry
- Food and beverage industry
- Water and waste water technology

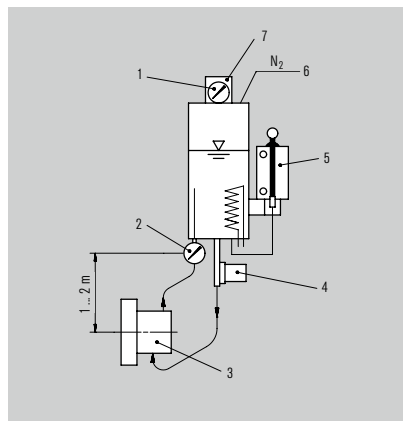
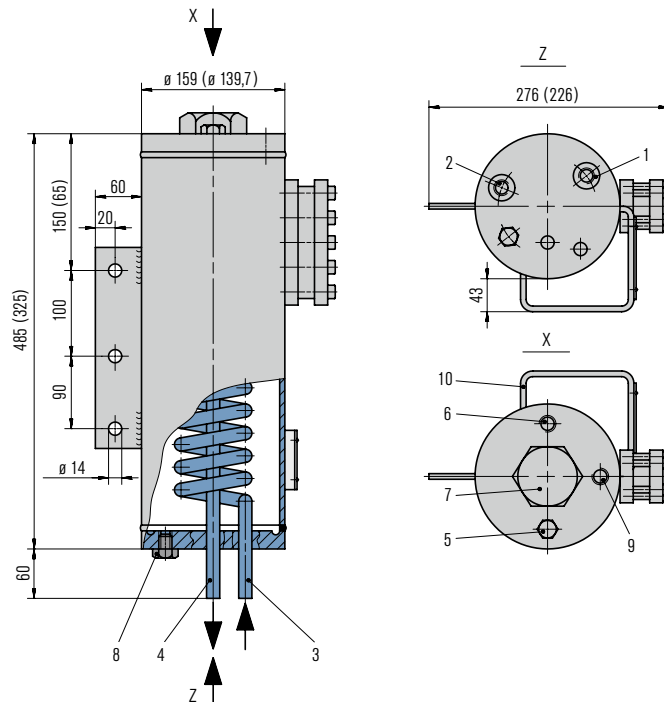

Operating and installation diagram for a TS1000 system.

The TS vessel must always be installed higher than the mechanical seal. The buffer/barrier fluid flows via the rising pipe into the vessel and is cooled. Particularly with natural circulation, the fluid level must always be higher than the rising pipe to maintain the circulation and to provide the specified cooling capacity. Connection pipes to the seal should be designed with as little resistance as possible.

- 1 Pressure gauge
- 2 Thermometer
- 3 Mechanical seal
- 4 SPU
- 5 SPN
- 6 From PCV, we recommend using a reverse controlled pressure control valve (PCV)
- 7 Level switch

Item Description

- | Item | Description |
|------|--------------------------------------|
| 1 | Buffer/barrier fluid IN (G1/2") |
| 2 | Buffer/barrier fluid OUT (G1/2") |
| 3 | Cooling water IN (pipe 12 x 1.5 mm) |
| 4 | Cooling water OUT (pipe 12 x 1.5 mm) |
| 5 | Filling connection with cap (G1/2") |
| 6 | Pressure gas connection (1/4 NPT) |
| 7 | Connection for level switch (G2") |
| 8 | Connection for refill unit (G1/8") |
| 9 | Connection for pressure gauge |
| 10 | Bracket for refill unit |

Dimensions for TS1016/A007
Values in brackets: TS1016/A003.

Product variants

TS1016/A003 **TS1016/A007**



Designation	TS1016/A003	TS1016/A013	TS1016/A007	TS1016/A008
Standard version	■		■	TS1016/A008
Pressure Equipment Directive	PED	PED	PED	PED
Integrated cooling coil	■		■	
Volume, vessel (liters)	4	4	8	8
Volume, tube (liters)	0.2		0.2	
Allowable pressure ¹⁾	16 bar (232 PSI)	16 bar (232 PSI)	16 bar (232 PSI)	16 bar (232 PSI)
Allowable temperature ¹⁾	-60 °C ... +160 °C (-76 °F ... +320 °F)	-60 °C ... +160 °C (-76 °F ... +320 °F)	-60 °C ... +200 °C (-76 °F ... +392 °F)	-60 °C ... +200 °C (-76 °F ... +392 °F)
Working volume, MAX-MIN (liters)	1.2	1.2	1.3	1.3
Cooling capacity - without cooling water (kW) ³⁾	0.2	0.2	0.3	0.3
Cooling capacity - natural circulation (kW) ²⁾	1		1.2	
Cooling capacity - forced circulation (kW) ²⁾	2		2.5	
Required cooling water quantity (m ³ /h)	0.25		0.3	
Metal parts	1.4571	1.4571	1.4571	1.4571
Sight-glass	Round Borosilicate	Reflex Borosilicate	Reflex Borosilicate	Reflex Borosilicate
Seal	PTFE	PTFE	PTFE	PTFE

Other versions on request.

¹⁾ Design data, permissible working values depend on the actual conditions of service.

²⁾ Guidelines with buffer/barrier fluid water 60 °C - cooling water 20 °C.

³⁾ Guidelines with buffer/barrier fluid water 60 °C - ambient temperature 20 °C (valid for thermosiphon systems without cooling water with natural circulation resp. forced circulation).

Pre-configured complete systems to cover main applications

Complete systems (selection)	TS1016/ M063-D1	TS1016/ M151-D1	TS1016/ M152-D1	TS1016/ M078-D1	TS1016/ M153-D1	TS1016/ M007-D0	TS1016/ M394-D1	TS1016/ M201-D0	TS1016/ M221-D1	TS1016/ M395-D1	TS1016/ M142-D1	TS1016/ M194-D1	TS1016/ M245-D0	TS1016/ M396-D1	TS1016/ M311-D1	TS1016/ M062-D1
Operation acc. to API Plan	Plan 53A															Plan 52
1 TS basic vessel																
A TS1016/A007-00 (8 liters, PED)	■	■	■	■	■	■	■	■	■	■	■	■	■	■	■	■
2 Pressure gauge																
A SP23-092-00 (PI 16 bar Ø63 ATEX)	■	■	■	■	■	■	■	■	■	■	■	■	■	■	■	■
B SP23-095-00 (PIA(L) 16 bar Ø100 ATEX)																
C SP23-451-00 (PIA(H) 16 bar Ø100 ATEX)																
O Without																
3 Thermometer																
A SP23-093-00 (TI 120 °C Ø63 ATEX)	■	■	■	■	■	■	■	■	■	■	■	■	■	■	■	■
B SP23-452-00 (TIA(H) 200 °C Ø100 ATEX)																
O Without																
4 Level switch																
A SPS2000-00 (LA(L) ATEX)	■	■	■	■	■	■	■	■	■	■	■	■	■	■	■	■
B SPS2000/A002-00 (LA(H/L) ATEX)																
O Without																
5 Refill pump																
A SPN4016-D0	■	■	■	■	■	■	■	■	■	■	■	■	■	■	■	■
B SPN2063-00																
C SPN2063/A200-00 (Borosilicate, stainless steel)																
O Without																
6 N₂ & Vent																
A SP17-006-00 (OUT: R1/4" (f))	■	■	■	■	■	■	■	■	■	■	■	■	■	■	■	■
B SP17-011-00 (OUT: tube end (Plan 52))																
O Without																
7 Drain																
A SP14-013-00 (OUT: R1/2" (f))	■	■	■	■	■	■	■	■	■	■	■	■	■	■	■	■
O Without																
8 Circulation pump																
A SPU5000-D0																

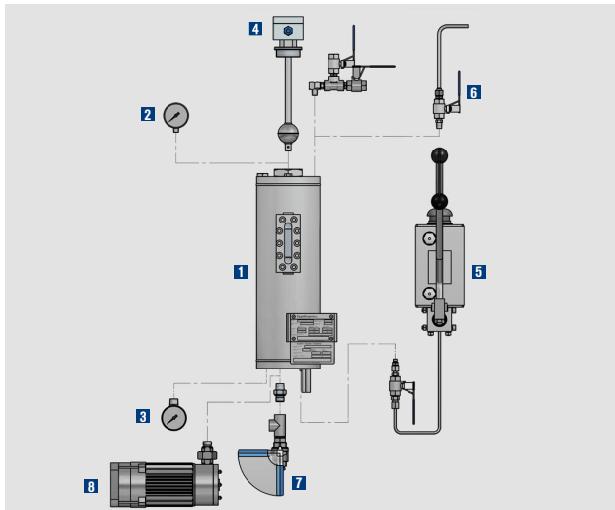

TS2000



Features

With the EagleBurgmann TS2000 thermosiphon system it is possible to supply buffer/barrier fluid to double and tandem mechanical seals for a broad range of applications. The range is available in 2 different pressure levels with dished heads, sight-glass for level monitoring and with or without cooling coil. TS vessels are equipped as standard with all the necessary system connections and brackets. The modular system allows the TS2000 vessels to be combined with a wide range of system components such as, level switch, circulation pump, hand refill pump, thermometer, base frame, etc.

Circulation in accordance with API 682 / ISO 21 049: Plan 52, Plan 53A.

Advantages

- Modular system: combination with a wide range of system components possible
- Vessel made of 1.4571 stainless steel / borosilicate sight-glasses: suitable for universal applications
- Available with or without cooling coil
- Sockets with recessed gasket: no contamination of the circuit by thread sealant

Functional description

The TS system performs all the basic functions of a buffer/barrier system for the operation of double seals:

- to pressurize the buffer chamber
- leakage compensation
- buffer/barrier fluid is circulated by thermosiphon effect or external circulation system
- to cool the seal
- to selectively absorb product leakage and prevent dry running (tandem arrangement)

Use compressed air or nitrogen for pressurization.

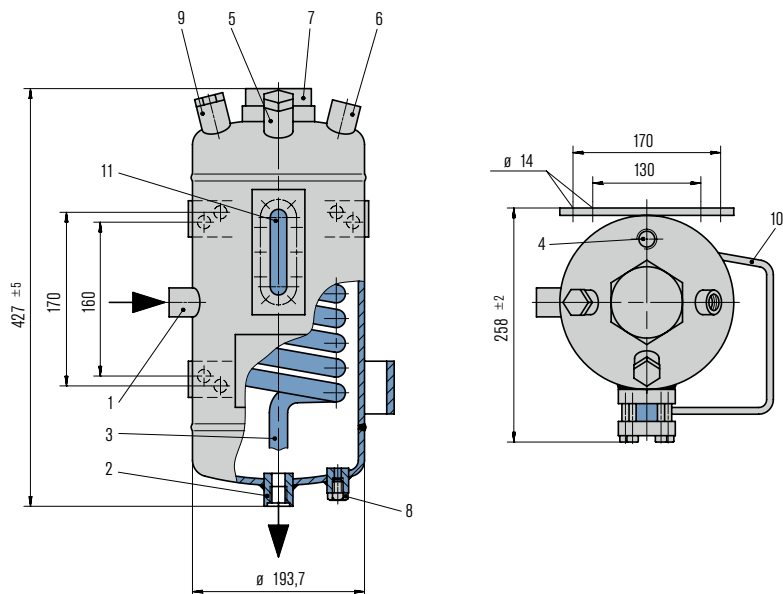

Item Description

- | Item | Description |
|------|--|
| 1 | Buffer/barrier fluid IN (G1/2") |
| 2 | Buffer/barrier fluid OUT (G1/2") |
| 3 | Cooling water IN (G1/2") |
| 4 | Cooling water OUT (G1/2") |
| 5 | Filling connection with cap (G1/2") |
| 6 | Pressure gas connection (G1/2") |
| 7 | Connection for level switch or level indicator (G 2") |
| 8 | Connection for refill unit (G1/8") |
| 9 | Universal connection (G1/2" for safety valve, flare, etc.) |
| 10 | Bracket for refill unit |
| 11 | Sight-glass |

Product variants

TS4030: A gap-free TS vessel, with a pickled and passivated surface.

TS5000: vessel can be dismantled

Standards and approvals

- PED 97/23 EC (Design and production in accordance with EU Pressure Equipment Directive)
- ASME VIII, Div. 1 (Design, calculation and production)

Recommended applications

- Chemical industry
- Petrochemical industry
- Oil and gas industry
- Refining technology

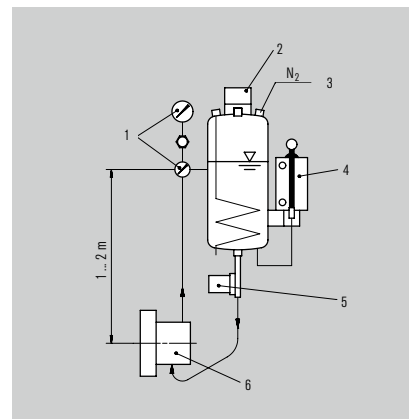

Operating and installation diagram for a TS2000 system.

The TS vessel must always be installed higher than the mechanical seal. The buffer/barrier fluid flows via the return pipe into the vessel and is cooled. The exchange of fluid takes place by the thermosiphon principle or by forced circulation, e.g. with a pumping screw. Connection pipes to the seal should be designed with as little resistance as possible.

- 1 SPI Measuring unit
- 2 SPS Level switch
- 3 From PCV, we recommend using a reverse controlled pressure control valve (PCV)
- 4 SPN
- 5 SPU
- 6 Mechanical seal

Designation	TS2000-00	TS2001-00	TS2063/A002	TS2063/A001	TS2000/A100	TS2001/A100	TS2063/A102	TS2063/A101
Pressure Equipment Directive	PED	PED	PED	PED	ASME	ASME	ASME	ASME
Integrated cooling coil	■	■	■	■	■	■	■	■
Volume, vessel (liters)	9	9	9	9	9	9	9	9
Volume, tube (liters)	0.5	0.5	0.5	0.5	0.5	0.5	0.5	0.5
Allowable pressure ¹⁾	30 bar (435 PSI)	30 bar (435 PSI)	63 bar (914 PSI)	63 bar (914 PSI)	20 bar (290 PSI)	20 bar (290 PSI)	52 bar (754 PSI)	52 bar (754 PSI)
Allowable temperature ¹⁾	-60 °C ... +200 °C (-76 °F ... +392 °F)	-60 °C ... +200 °C (-76 °F ... +392 °F)	-60 °C ... +200 °C (-76 °F ... +392 °F)	-60 °C ... +200 °C (-76 °F ... +392 °F)	-29 °C ... +150 °C (-20 °F ... +302 °F)	-29 °C ... +150 °C (-20 °F ... +302 °F)	-29 °C ... +200 °C (-20 °F ... +392 °F)	-29 °C ... +200 °C (-20 °F ... +392 °F)
Working volume, MAX-MIN (liters)	1.8	1.8	1.8	1.8	1.8	1.8	1.8	1.8
Cooling capacity – without cooling water (kW) ³⁾	0.5	0.5	0.5	0.5	0.5	0.5	0.5	0.5
Cooling capacity – natural circulation (kW) ²⁾	1.5	1.5	1.5	1.5	1.5	1.5	1.5	1.5
Cooling capacity – forced circulation (kW) ²⁾	4	4	4	4	4	4	4	4
Required cooling water quantity (m ³ /h)	0.4	0.4	0.4	0.4	0.4	0.4	0.4	0.4
Metal parts	1.4571	1.4571	1.4571	1.4571	1.4571	1.4571	1.4571	1.4571
Sight-glass	Reflex Borosilicate	Reflex Borosilicate	Reflex Borosilicate	Reflex Borosilicate	Reflex Borosilicate	Reflex Borosilicate	Reflex Borosilicate	Reflex Borosilicate
Seal	PTFE	PTFE	PTFE	PTFE	PTFE	PTFE	PTFE	PTFE
Net weight (approx.)	15.5 kg (34 lb)	12.5 kg (28 lb)	28.5 kg (63 lb)	26 kg (57 lb)	15.5 kg (34 lb)	12.5 kg (28 lb)	28.5 kg (63 lb)	26 kg (57 lb)

Other versions on request.

¹⁾ Design data, permissible working values depend on the actual conditions of service.

²⁾ Guidelines with buffer/barrier fluid water 60 °C – cooling water 20 °C.

³⁾ Guidelines with buffer/barrier fluid water 60 °C – ambient temperature 20 °C (valid for thermosiphon systems without cooling water with natural circulation resp. forced circulation).

Pre-configured complete systems to cover main applications

Complete systems (selection)	TS2000/ M263-D1	TS2000/ M664-D1	TS2000/ M195-D0	TS2000/ M630-D1	TS2000/ M581-D0	TS2000/ M564-D1	TS2000/ M568-D1	TS2000/ M613-D1	TS2000/ M166-D0	TS2000/ M091-D0	TS2000/ M173-D0	TS2000/ M569-D1	TS2000/ M537-D1	TS2000/ M699-D1	TS2000/ M399-D1	TS2000/ M493-D1	TS2000/ M262-D1
Operation acc. to API Plan	Plan 53A																Plan 52
1 TS basic vessel	■																
A TS2000-00 (9 liters, PED)	■	■	■	■	■	■	■	■	■	■	■	■	■	■	■	■	■
2 Measuring unit	■																
A SPI2000-00 (PI 40 bar Ø100 ATEX TI 200 °C Ø63 ATEX)	■	■	■	■	■	■	■	■	■	■	■	■	■	■	■	■	■
B SPI2000/A049-00 (PIA(L) 40 bar Ø100 ATEX TI 200 °C Ø63 ATEX)	■	■	■	■	■	■	■	■	■	■	■	■	■	■	■	■	■
C SPI2000/A159-00 (PIA(L) 40 bar Ø100 ATEX TIA(H) 200 °C Ø100 ATEX)	■	■	■	■	■	■	■	■	■	■	■	■	■	■	■	■	■
D SPI2000/A160-00 (PIA(H) 16 bar*) Ø100 ATEX TI 200 °C Ø63 ATEX)	■	■	■	■	■	■	■	■	■	■	■	■	■	■	■	■	■
E SPI2000/A161-00 (PIA(H) 16 bar*) Ø100 ATEX TIA(H) 200 °C Ø100 ATEX)	■	■	■	■	■	■	■	■	■	■	■	■	■	■	■	■	■
F SPI2000/A003-00 (PIA(H/L) 40 bar Ø100 ATEX TIA(H/L) 200 °C Ø100 ATEX)	■	■	■	■	■	■	■	■	■	■	■	■	■	■	■	■	■
O Without	■																
3 Level switch	■																
A SPS2000-00 (LA(L) ATEX)	■	■	■	■	■	■	■	■	■	■	■	■	■	■	■	■	■
B SPS2000/A002-00 (LA(H/L) ATEX)	■	■	■	■	■	■	■	■	■	■	■	■	■	■	■	■	■
O Without	■																
4 Refill pump	■																
A SPN4016-D0 (Refill pressure max. 16 bar)	■	■	■	■	■	■	■	■	■	■	■	■	■	■	■	■	■
B SPN2063-00	■	■	■	■	■	■	■	■	■	■	■	■	■	■	■	■	■
C SPN2063/A200-00 (Borosilicate, stainless steel)	■	■	■	■	■	■	■	■	■	■	■	■	■	■	■	■	■
O Without	■																
5 N₂ & Vent	■																
A SP17-029-D1 (OUT: R1/4" (f))	■	■	■	■	■	■	■	■	■	■	■	■	■	■	■	■	■
B SP17-010-00 (OUT: tube end (Plan 52))	■	■	■	■	■	■	■	■	■	■	■	■	■	■	■	■	■
O Without	■																
6 Drain	■																
A SP14-039-D1 (OUT: R1/2" (f))	■	■	■	■	■	■	■	■	■	■	■	■	■	■	■	■	■
O Without	■																
7 Circulation pump	■																
A SPU5000-D0	■	■	■	■	■	■	■	■	■	■	■	■	■	■	■	■	■

^{*)} 3 times overrange protected

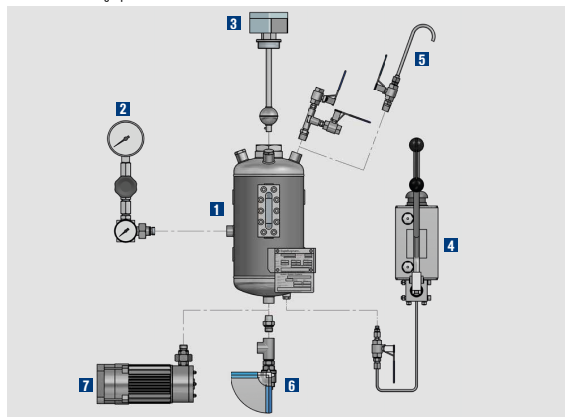

TS3000

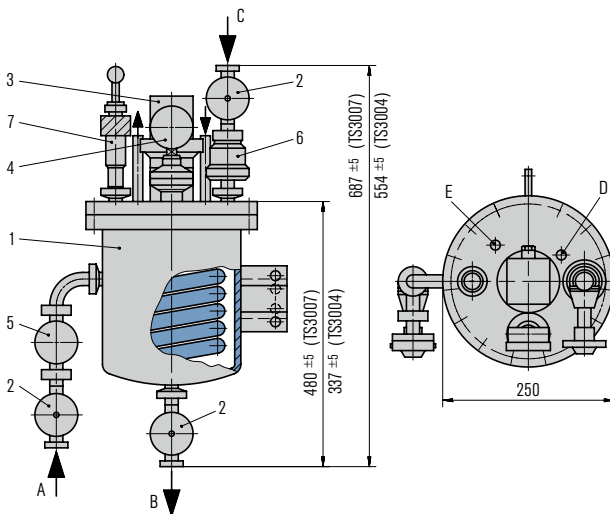

Features

Thermosiphon systems of the TS3000 range designed specifically for the operation and supply of mechanical seals in sterile processes. The TS3000 thermosiphon vessel is available in two standard sizes, designed for dismantling, with cooling coil. The modular system allows the TS3000 vessels to be combined with a wide range of system components.

Circulation in accordance with API 682/ISO 21 049: Plan 52, Plan 53A.

Advantages

- Can be fully sterilized: TS3000 thermosiphon system, including all components and pipe couplings
- Surfaces are electropolished on all sides: effective cleaning and reduction of bacteria growth
- Vessel can be dismantled: the joint is sealed at the inner diameter by an O-Ring without any gaps
- FDA-conform materials, therefore suitable for hygienic applications

Functional description

The TS system performs all the basic functions of a buffer/barrier system for the operation of double seals:

- to pressurize the buffer chamber
- leakage compensation
- buffer/barrier fluid is circulated by thermosiphon effects or forced circulation system
- to cool the seal
- to selectively absorb product leakage and prevent dry running (tandem arrangement)

In addition to performing the basic functions of a buffer/barrier system, the TS3000 system can also be used to make condensate, provided the TS system is connected up to a steam pipe.

Item Description

- | | |
|---|--------------------------------------|
| 1 | TS vessel with cooling coil |
| 2 | Shut-off valve |
| 3 | Level switch |
| 4 | Pressure gauge (membrane transducer) |
| 5 | Thermometer |
| 6 | Check valve |
| 7 | Safety valve (set pressure 8 bar) |

- | | |
|---|--------------------------|
| A | Buffer/barrier fluid IN |
| B | Buffer/barrier fluid OUT |
| C | Pressure gas connection |
| E | Cooling water OUT |
| D | Cooling water IN |

Standards and approvals

- PED 97/23 EC (Design and production in accordance with EU Pressure Equipment Directive)

Recommended applications

- Food and beverage industry
- Pharmaceutical industry

Notes

Sterilization: CIP and SIP is possible.
Making condensate: At the end of the sterilization cycle, valve 2.4 is closed, valve 2.3 is fully opened and the cooling water supply is switched on again – condensate will be made.
 The level switch (3) responds when the TS vessel is full.
 The agitator can be started up again.

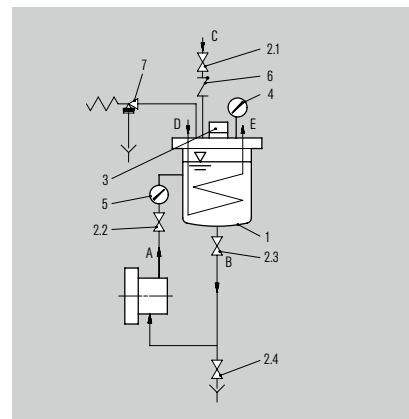

Operating and installation diagram for a TS3000 system

The TS vessel must always be installed higher than the mechanical seal. The buffer/barrier fluid flows via the return pipe into the vessel and is cooled. The exchange of fluid takes place by the thermosiphon principle or by forced circulation, e.g. with a pumping screw. Connection pipes to the seal should be designed with as little resistance as possible.

Designation	TS3004	TS3007
Pressure Equipment Directive	PED	PED
Integrated cooling coil	■	■
Volume, vessel (liters)	3.5	6.7
Volume, tube (liters)	0.2	0.5
Allowable pressure ¹⁾	8 bar (116 PSI)	8 bar (116 PSI)
Allowable temperature ¹⁾	-10 °C ... +140 °C (14 °F ... + 284 °F)	-10 °C ... +140 °C (14 °F ... + 284 °F)
Cooling capacity – natural circulation (kW) ²⁾	1	2
Cooling capacity – forced circulation (kW) ²⁾	2	4
Metal parts	1.4571	1.4571
Seal	EPDM	EPDM

¹⁾ Design data, permissible working values depend on the actual conditions of service
²⁾ Guidelines with buffer/barrier fluid water 60 °C – cooling water 20 °C

TS3016

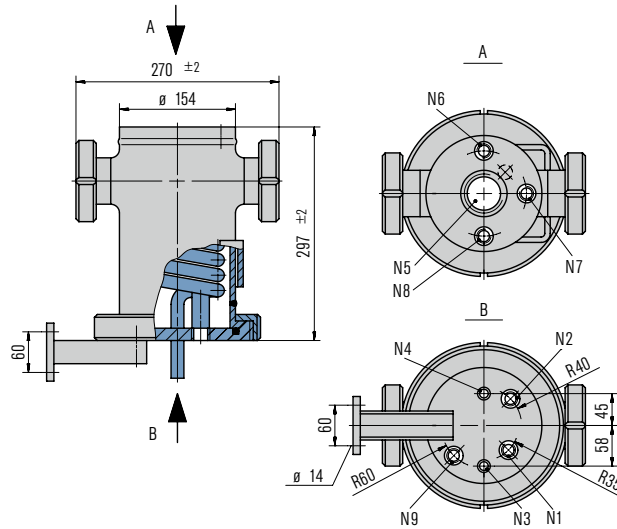

Features

The EagleBurgmann TS3016 thermosiphon system presents a simple and quick way to clean the vessel interior. For this purpose it is designed for easy dismantling. A quick-release coupling should therefore be used to connect the pressure gas to the vessel. The modular system allows the TS3016 vessels to be combined with a wide range of system components.

Circulation in accordance with API 682/ISO 21 049: Plan 52, Plan 53A

Advantages

- Vessel can be dismantled: for optimum and simple cleaning of the vessel interior
- Innovative design: Vessel is designed for quick and simple dismantling
- Two sight-glasses fitted on opposite sides enable optimum reading of the fluid level
- Piping system and seal can be flushed without dismantling
- Modular system: combination with a wide range of system components possible

Functional description

The TS system performs all the basic functions of a buffer/barrier system for the operation of double seals:

- to pressurize the buffer/barrier chamber
- leakage compensation
- buffer/barrier fluid is circulated by thermosiphon effect or forced circulation system
- to cool the seal
- to selectively absorb product leakage and prevent dry running (tandem arrangement)

Use compressed air or nitrogen for pressurization.

Item Description

Item	Description
N1	Buffer/barrier fluid IN G1/2"
N2	Buffer/barrier fluid OUT G1/2"
N3	Cooling water IN Tubes 15 x 1.5 mm
N4	Cooling water OUT Tubes 15 x 1.5 mm
N5	Level switch G2"
N6	Auxiliary components G1/2"
N7	Auxiliary components G1/2"
N8	Filling connection (G1/2")
N9	Drain G1/2"

Standards and approvals

- PED 97/23 EC (Design and production in accordance with EU Pressure Equipment Directive)

Recommended applications

- Food and beverage industry
- Pharmaceutical industry
- Chemical industry

Notes

Cleaning:

To clean the inside of the vessel you simply have to open the union nut, disconnect the gas supply and level switch, and lift the vessel case.

There is no need to dismantle the seal and cooler connections or the lase.

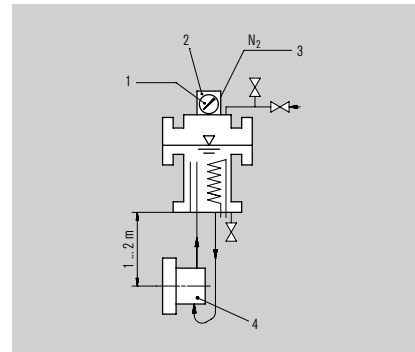

Operating and installation diagram for a TS3016 system

The TS vessel must always be installed higher than the mechanical seal. The buffer/barrier fluid flows via the rising pipe into the vessel and is cooled. Particularly with natural circulation, the fluid level must always be higher than the rising pipe to maintain the circulation and to provide the specified cooling capacity. Connection pipes to the seal should be designed with as little resistance as possible.

- 1 Pressure gauge
- 2 SPS Level switch
- 3 From PCV, we recommend using a reverse controlled pressure control valve (PCV)
- 4 Mechanical seal

Designation TS3016

Pressure Equipment Directive	PED
Integrated cooling coil	■
Volume, vessel (liters)	4
Volume, tube (liters)	0.4
Allowable pressure ¹⁾	16 bar (232 PSI)
Allowable temperature ¹⁾	150 °C (302 °F)
Working volume, MAX-MIN (liters)	1.1
Cooling capacity – natural circulation (kW) ²⁾	1
Cooling capacity – forced circulation (kW) ²⁾	2
Metal parts	1.4404
Sight-glass	Rund Borosilicate
Seal	PTFE
Additional welding material	1.4576/1.4430
Net weight (approx.)	12 kg (26.5 lb)

¹⁾ Design data, permissible working values depend on the actual conditions of service

²⁾ Guidelines with buffer/barrier fluid water 60 °C – cooling water 20 °C

TS4000

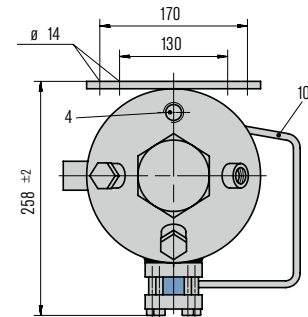
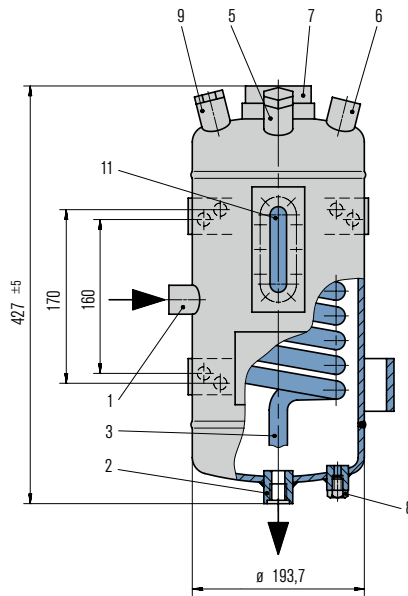

Features

With the gap-free executed EagleBurgmann TS4000 thermosiphon system it is possible to supply buffer/barrier fluid to double and tandem mechanical seals for a broad range of applications. The range is available in completely gap-free design with dished heads, sight-glass for level monitoring and with cooling coil. TS vessels are equipped as standard with all the necessary system connections and brackets. The modular system allows the TS4000 vessels to be combined with a wide range of system components such as, level switch, circulation pump, hand refill pump, thermometer, etc.

Circulation in accordance with API 682/ISO 21 049: Plan 52, Plan 53A

Advantages

- Gap-free design; pickled and passivated surface inside and outside
- Suitable for a wide range of demanding operating conditions: TS4030 up to 30 bar/200 °C
- Cooling water connections at top (OUT) and bottom (IN): optimum draining and venting
- Sockets with recessed gasket: no contamination of the circuit by thread sealant
- Robust design with weld-pad type sight-glass for optimum visual level monitoring
- Modular system: combination with a wide range of system components possible

Functional description

The TS system performs all the basic functions of a buffer/barrier system for the operation of double seals:

- to pressurize the buffer/barrier chamber
- leakage compensation
- buffer/barrier fluid is circulated by thermosiphon effect or forced circulation system
- to cool the seal
- to selectively absorb product leakage and prevent dry running (tandem arrangement)

Use compressed air or nitrogen for pressurization.

Item Description

- | Item | Description |
|------|--|
| 1 | Buffer/barrier fluid IN (G1/2") |
| 2 | Buffer/barrier fluid OUT (G1/2") |
| 3 | Cooling water IN (G1/2") |
| 4 | Cooling water OUT (G1/2") |
| 5 | Filling connection with cap (G1/2") |
| 6 | Pressure gas connection (G1/2") |
| 7 | Connection for level switch or level indicator (G2") |
| 8 | Connection for refill unit (G1/8") |
| 9 | Universal connection (G1/2") for safety valve, flare, etc. |
| 10 | Bracket for refill unit |
| 11 | Sight-glass |

Standards and approvals

- PED 97/23 EC (Design and production in accordance with EU Pressure Equipment Directive)

Recommended applications

- Chemical industry
- Pharmaceutical industry
- Food and beverage industry
- Refining technology
- Oil and gas industry

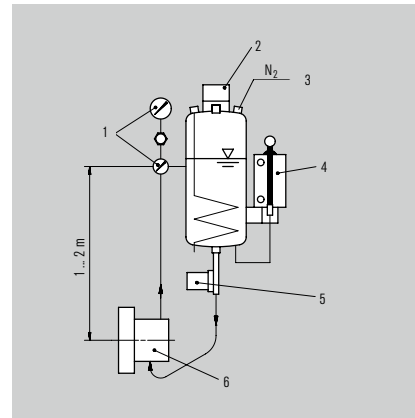

Operating and installation diagram for a TS4000 system.

The TS vessel must always be installed higher than the mechanical seal. The buffer/barrier fluid flows via the return pipe into the vessel and is cooled. The exchange of fluid takes place by the thermosiphon principle or by forced circulation, e.g. with a pumping screw. Connection pipes to the seal should be designed with as little resistance as possible.

- 1 SPI Measuring unit
- 2 SPS Level switch
- 3 From PCV, we recommend using a reverse controlled pressure control valve (PCV)
- 4 SPN
- 5 SPU
- 6 Mechanical seal

Designation	TS4030/A002
Pressure Equipment Directive	PED
Integrated cooling coil	■
Volume, vessel (liters)	9
Volume, tube (liters)	0.5
Allowable pressure ¹⁾	30 bar (435 PSI)
Allowable temperature ¹⁾	-60 °C ... +200 °C (-76 °F ... +392 °F)
Working volume, MAX-MIN (liters)	1.8
Cooling capacity – without cooling water (kW) ³⁾	0.5
Cooling capacity – natural circulation (kW) ²⁾	1.5
Cooling capacity – forced circulation (kW) ²⁾	4
Required cooling water quantity (m ³ /h)	0.4
Metal parts	1.4571
Sight-glass	Reflex Borosilicate
Seal	PTFE

Other versions on request.

¹⁾ Design data, permissible working values depend on the actual conditions of service

²⁾ Guidelines with buffer/barrier fluid water 60 °C – cooling water 20 °C

³⁾ Guidelines with buffer/barrier fluid water 60 °C – ambient temperature 20 °C (valid for thermosiphon systems without cooling water with natural circulation resp. forced circulation)

TS5000



Features

With the gap-free executed EagleBurgmann TS5000 thermosiphon system it is possible to supply buffer/barrier fluid to double and tandem mechanical seals for a broad range of applications. This range is designed as a flanged version with a sight-glass for level monitoring and with cooling coil. TS vessels are equipped as standard with all the necessary system connections and brackets. The modular system allows the TS5000 vessels to be combined with a wide range of system components such as, level switch, circulation pump, hand refill pump, thermometer, base frame, etc.

Circulation in accordance with API 682/ISO 21 049: Plan 52, Plan 53A

Advantages

- Vessel can be dismantled: for optimum and simple cleaning of the vessel interior
- Suitable for a wide range of demanding operating conditions: TS5000 up to 30 bar/200 °C
- Sockets with recessed gasket: no contamination of the circuit by thread sealant
- Modular system: combination with a wide range of system components possible
- Vessel made of 1.4571 stainless steel/borosilicate sight-glasses: suitable for universal applications

Functional description

The TS system performs all the basic functions of a buffer/barrier system for the operation of double seals:

- to pressurize the buffer/barrier chamber
- leakage compensation
- buffer/barrier fluid is circulated by thermosiphon effect or forced circulation system
- to cool the seal
- to selectively absorb product leakage and prevent dry running (tandem arrangement)

Use compressed air or nitrogen for pressurization.

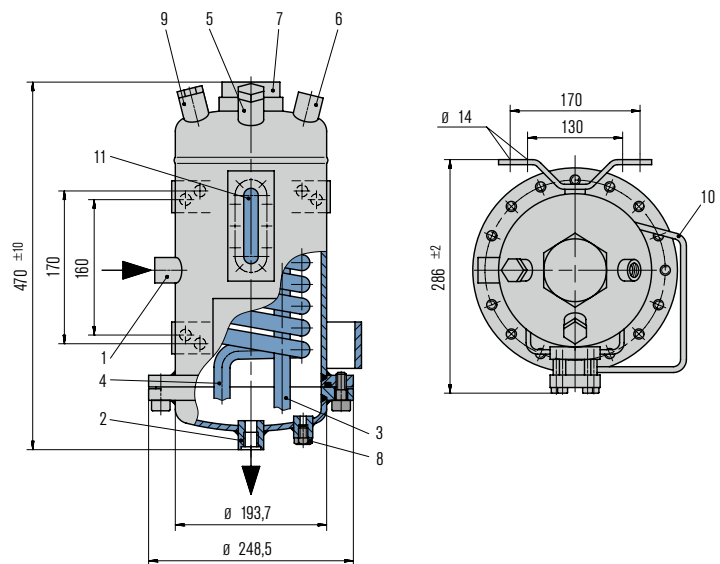

Item Description

Item	Description
1	Buffer/barrier fluid IN (G1/2")
2	Buffer/barrier fluid OUT (G1/2")
3	Cooling water IN (G1/2")
4	Cooling water OUT (G1/2")
5	Filling connection with cap (G1/2")
6	Pressure gas connection (G1/2")
7	Connection for level switch or level indicator (G2")
8	Connection for refill unit (G1/8")
9	Universal connection (G1/2" for safety valve, flare, etc.)
10	Bracket for refill unit
11	Sight-glass

Standards and approvals

- PED 97/23 EC (Design and production in accordance with EU Pressure Equipment Directive)

Recommended applications

- Chemical industry
- Petrochemical industry
- Oil and gas industry
- Refining technology

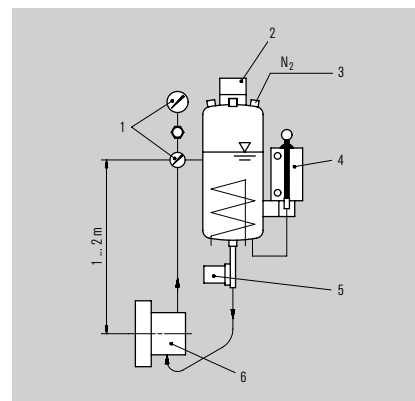

Operating and installation diagram for a TS5000 system.

The TS vessel must always be installed higher than the mechanical seal. The buffer/barrier fluid flows via the return pipe into the vessel and is cooled. The exchange of fluid takes place by the thermosiphon principle or by forced circulation, e.g. with a pumping screw. Connection pipes to the seal should be designed with as little resistance as possible.

- 1 SPI
- 2 SPS
- 3 From PCV, we recommend using a reverse controlled pressure control
- 4 SPN
- 5 SPU
- 6 Mechanical seal

Designation	TS5000
Pressure Equipment Directive	PED
Integrated cooling coil	■
Volume, vessel (liters)	10
Volume, tube (liters)	0.5
Allowable pressure ¹⁾	30 bar (435 PSI)
Allowable temperature ¹⁾	-60 °C ... +200 °C (-76 °F ... +392 °F)
Working volume, MAX-MIN (liters)	1.8
Cooling capacity – without cooling water (kW) ³⁾	0.5
Cooling capacity – natural circulation (kW) ²⁾	1.5
Cooling capacity – forced circulation (kW) ²⁾	4
Required cooling water quantity (m ³ /h)	0.4
Metal parts	1.4571
Sight-glass	Reflex Borosilicate
Seal	PTFE

Other versions on request.

¹⁾ Design data, permissible working values depend on the actual conditions of service

²⁾ Guidelines with buffer/barrier fluid water 60 °C – cooling water 20 °C

³⁾ Guidelines with buffer/barrier fluid water 60 °C – ambient temperature 20 °C (valid for thermosiphon systems without cooling water with natural circulation resp. forced circulation)

TS6000 / TSA6 / TSB6



Features

The EagleBurgmann Thermosiphon systems of the TS6000 range meet all the requirements to supply mechanical seals in accordance with the API 682 guidelines. The vessels are equipped with all essential connections for fitting additional components. The range is available in two standard vessel sizes (shown above: TS6000) with dished heads; a version which can be dismantled is also available as an option. The modular system allows the TS6000 vessels to be combined with a wide range of system components such as, level switch/transmitter, pressure switch/transmitter, base frame, etc.

Circulation in accordance with API 682/ISO 21 049: Plan 52, Plan 53A

Advantages

- Operating limits up to 50 bar/200 °C: suitable for a wide range of demanding operating conditions
- Robust design with weld-pad type sight-glass for optimum visual level monitoring
- Modular system: combination with a wide range of system components possible
- A version which can be dismantled is also available as an option: for optimum and simple cleaning of the vessel interior

Functional description

The TS system performs all the basic functions of a buffer/barrier system for the operation of double seals:

- to pressurize the buffer/barrier chamber
- leakage compensation
- buffer/barrier fluid is circulated by thermosiphon effect or forced circulation system
- to cool the seal
- to selectively absorb product leakage and prevent dry running (tandem arrangement)

Use compressed air or nitrogen for pressurization; pressurization is monitored by a pressure switch. The incorporated level switch issues a signal whenever the level of buffer/barrier fluid is too low.

Standards and approvals

- PED 97/23 EC (TS6001/TS6003: design and production in accordance with EU Pressure Equipment Directive)
- ASME VIII, Div. 1 (TS6000/TS6002: design, calculation and production)

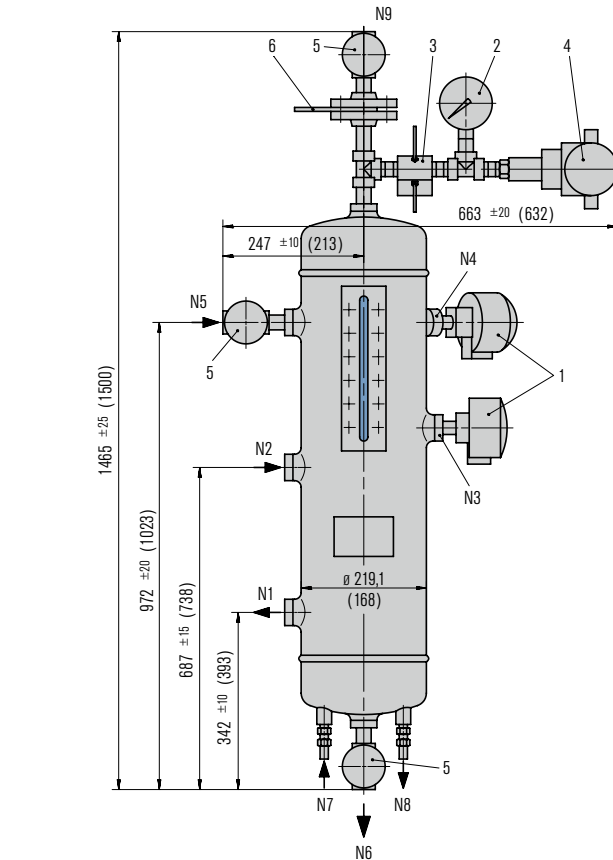

Item Description

Thermosiphon system (API Plan 52)

- | | |
|---|-----------------|
| 1 | Level switch |
| 2 | Manometer |
| 3 | Manifold |
| 4 | Pressure switch |
| 5 | Shut-off valve |
| 6 | Orifice |

- | | |
|----|----------------------|
| N1 | To mechanical seal |
| N2 | From mechanical seal |
| N3 | Level switch |
| N4 | Level switch |
| N5 | Filling connection |

Bottom

- | | |
|----|-------------------|
| N6 | Drain |
| N7 | Cooling water IN |
| N8 | Cooling water OUT |

Cover

- | | |
|----|---------------------|
| N9 | Connection to flare |
|----|---------------------|

Dimensions for TS6002 / TS6003, values in brackets for TS6000 / TS6001

Recommended applications

- Refining technology
- Oil and gas industry
- Chemical industry
- Petrochemical industry

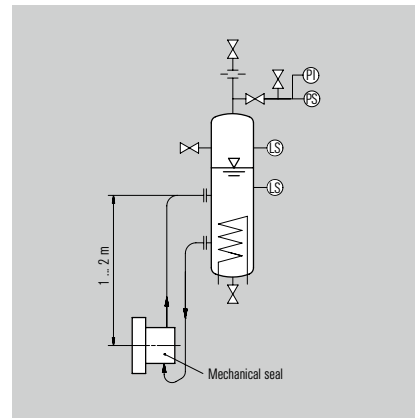

Operating and installation diagram for a TS6000 system.

The TS vessel must always be installed higher than the mechanical seal. The buffer/barrier fluid flows via the return pipe into the vessel and is cooled. The exchange of fluid takes place by the thermosiphon principle or by forced circulation, e.g. with a pumping screw. Connection pipes to the seal should be designed with as little resistance as possible.

Designation	TS6000	TS6001	TS6002	TS6003
Pressure Equipment Directive	ASME	PED	ASME	PED
For shaft diameters ≤60 mm (acc. to API 682)	■	■	■	■
For shaft diameters >60 mm (acc. to API 682)	■	■	■	■
Integrated cooling coil	■	■	■	■
Volume, vessel (liters)	15	15	26	26
Volume, tube (liters)	0.3	0.3	0.4	0.4
Allowable pressure – shell ¹⁾	50 bar (725 PSI)	50 bar (725 PSI)	50 bar (725 PSI)	50 bar (725 PSI)
Allowable pressure – tube ¹⁾	50 bar (725 PSI)	50 bar (725 PSI)	50 bar (725 PSI)	50 bar (725 PSI)
Allowable temperature ¹⁾	200 °C (392 °F)	200 °C (392 °F)	200 °C (392 °F)	200 °C (392 °F)
Liquid volume at NLL – Normal Liquid Level (liters)	12	12	20	20
Working volume, MAX-MIN (liters)	4	4	6.5	6.5
Cooling capacity – without cooling water (kW) ³⁾	0.75	0.75	1	1
Cooling capacity – natural circulation (kW) ²⁾	1.9	1.9	2.5	2.5
Cooling capacity – forced circulation (kW) ²⁾	5	5	6.5	6.5
Required cooling water quantity (m ³ /h)	0.4	0.4	0.7	0.7
Metal parts	1.4404	1.4404	1.4404	1.4404
Sight-glass	Borosilicate	Borosilicate	Borosilicate	Borosilicate
Seal	PTFE	PTFE	PTFE	PTFE
Net weight (approx.)	68 kg (150 lb)	68 kg (150 lb)	75 kg (165 lb)	75 kg (165 lb)

Other versions on request.

¹⁾ Design data, permissible working values depend on the actual conditions of service

²⁾ Guidelines with buffer/barrier fluid water 60 °C – cooling water 20 °C

³⁾ Guidelines with buffer/barrier fluid water 60 °C – ambient temperature 20 °C (valid for thermosiphon systems without cooling water with natural circulation resp. forced circulation)

Product variants

TSA6

TSB6

Version of a TS vessel which can be dismantled (shown with a range of system components).

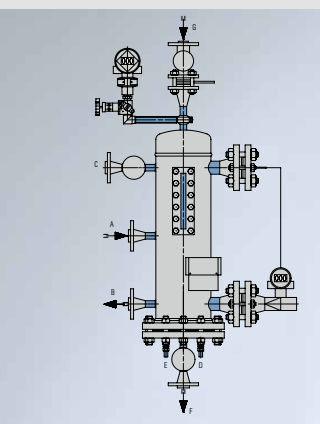

Designation	TSA6000-A4	TSA6001-A4	TSA6002-A4	TSA6003-A4	TSB6000-A4	TSB6001-A4	TSB6002-A4	TSB6003-A4
Pressure Equipment Directive	ASME	PED	ASME	PED	ASME	PED	ASME	PED
For shaft diameters ≤60 mm (acc. to API 682)	■	■			■	■		
For shaft diameters >60 mm (acc. to API 682)			■	■			■	■
Split version					■	■	■	■
Integrated cooling coil	■	■	■	■	■	■	■	■
Volume, vessel (liters)	15	15	26	26	15	15	26	26
Volume, tube (liters)	0.3	0.3	0.4	0.4	0.3	0.3	0.4	0.4
Allowable pressure – shell ¹⁾	44 bar (638 PSI)	44 bar (638 PSI)	44 bar (638 PSI)	44 bar (638 PSI)	44 bar (638 PSI)	44 bar (638 PSI)	44 bar (638 PSI)	44 bar (638 PSI)
Allowable pressure – tube ¹⁾	44 bar (638 PSI)	44 bar (638 PSI)	44 bar (638 PSI)	44 bar (638 PSI)	44 bar (638 PSI)	44 bar (638 PSI)	44 bar (638 PSI)	44 bar (638 PSI)
Allowable temperature – vessel ¹⁾	-29 °C ... +260 °C (-20 °F ... +500 °F)	-29 °C ... +260 °C (-20 °F ... +500 °F)	-29 °C ... +260 °C (-20 °F ... +500 °F)	-29 °C ... +260 °C (-20 °F ... +500 °F)	-29 °C ... +260 °C (-20 °F ... +500 °F)	-29 °C ... +260 °C (-20 °F ... +500 °F)	-29 °C ... +260 °C (-20 °F ... +500 °F)	-29 °C ... +260 °C (-20 °F ... +500 °F)
Allowable temperature – system ¹⁾	-29 °C ... +260 °C (-20 °F ... +500 °F)	-29 °C ... +260 °C (-20 °F ... +500 °F)	-29 °C ... +260 °C (-20 °F ... +500 °F)	-29 °C ... +260 °C (-20 °F ... +500 °F)	-29 °C ... +260 °C (-20 °F ... +500 °F)	-29 °C ... +260 °C (-20 °F ... +500 °F)	-29 °C ... +260 °C (-20 °F ... +500 °F)	-29 °C ... +260 °C (-20 °F ... +500 °F)
Liquid volume at NLL – Normal Liquid Level (liters)	12	12	20	20	12	12	20	20
Working volume, MAX-MIN (liters)	4	4	6.5	6.5	4	4	6.5	6.5
Cooling capacity – without cooling water (kW) ³⁾	0.75	0.75	1	1	0.75	0.75	1	1
Cooling capacity – natural circulation (kW) ²⁾	1.9	1.9	2.5	2.5	1.9	1.9	2.5	2.5
Cooling capacity – forced circulation (kW) ²⁾	5	5	6.5	6.5	5	5	6.5	6.5
Required cooling water quantity (m ³ /h)	0.4	0.4	0.7	0.7	0.4	0.4	0.7	0.7
Metal parts	316L	316L	316L	316L	316L	316L	316L	316L
Sight-glass	Borosilicate	Borosilicate	Borosilicate	Borosilicate	Borosilicate	Borosilicate	Borosilicate	Borosilicate
Seal	PTFE	PTFE	PTFE	PTFE	PTFE	PTFE	PTFE	PTFE
Net weight (approx.)	68 kg (150 lbs)	68 kg (150 lbs)	75 kg (165 lbs)	75 kg (165 lbs)				

Other versions on request.

¹⁾ Design data, permissible working values depend on the actual conditions of service.

²⁾ Guidelines with buffer/barrier fluid water 60 °C – cooling water 20 °C

³⁾ Guidelines with buffer/barrier fluid water 60 °C – ambient temperature 20 °C (valid for thermosiphon systems without cooling water with natural circulation resp. forced circulation)

SPO / SPB6 (Plan 53B)



Features

Pressurized barrier system (closed circuit) for use in seal systems with high pressures and/or for hazardous/ environmentally harmful processes. The SPO (Plan 53B) range is available with a pressure accumulator, cooler (finned tube, water or air cooler with fan) and a wide range of instruments.

Circulation in accordance with API 682/ISO 21 049: Plan 53B

Advantages

- Pressurization is by means of a pre-loaded bladder accumulator
- The nitrogen is separated from the barrier medium by membranes in the accumulator: nitrogen cannot get into the barrier medium or process medium
- Barrier pressure is created without any need for connection to a nitrogen supply
- Available with finned tube, water or air coolers with fan
- Modular system: combination with a wide range of system components/instruments possible

Functional description

The SPO is designed to perform the following functions of a barrier system:

- to pressurize the buffer chamber
- leakage compensation
- to cool the seal

Pressurization (> process pressure) prevents the process medium from getting into the barrier circuit or the atmosphere. Pressurization is supplied by a pressure accumulator which is pre-loaded with nitrogen. Circulation in the barrier circuit takes place by the thermosiphon principle or by forced circulation, e.g. with a pumping screw.

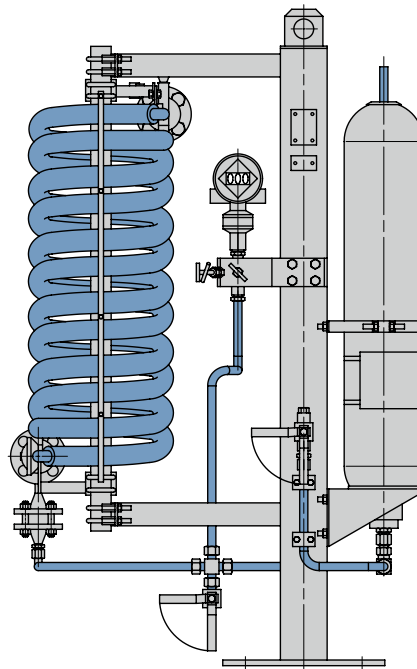

SPB6002-A4
with Air cooler

Standards and approvals

- PED 97/23 EC (Design and production in accordance with EU Pressure Equipment Directive)
- ASME VIII, Div. 1 (Design, calculation and production)

Recommended applications

- Petrochemical industry
- Chemical industry
- Oil and gas industry
- Refining technology

Notes

A refilling unit has to be provided.

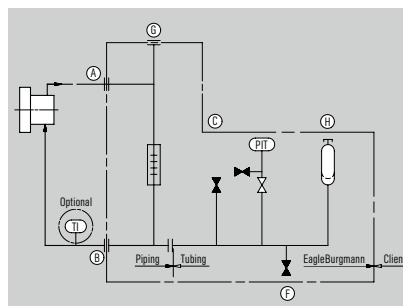

Funktions- und Installationsschema SPO, Plan 53B

- | | |
|---|--------------------------|
| A | From mechanical seal |
| B | To mechanical seal |
| C | Fill |
| F | Drain |
| G | Vent |
| H | N ₂ Precharge |

Product variant

SPO with a water cooler



Designation	SPB6000-A4		SPB6001-A4		SPB6002-A4		SPB6003-A4	
	ASME		PED		ASME		PED	
Pressure Equipment Directive	Air cooler ⁴⁾	Water cooler ⁴⁾	Air cooler ⁴⁾	Water cooler ⁴⁾	Air cooler ⁴⁾	Water cooler ⁴⁾	Air cooler ⁴⁾	Water cooler ⁴⁾
Type of heat exchanger	■		■		■		■	
For shaft diameters ≤ 60 mm (acc. to API 682)	■		■		■		■	
For shaft diameters > 60 mm (acc. to API 682)	■		■		■		■	
Bladder accumulator (liters)	20		20		35		35	
Allowable pressure ¹⁾	44 bar (638 PSI)		44 bar (638 PSI)		44 bar (638 PSI)		44 bar (638 PSI)	
Allowable temperature – bladder accumulator ¹⁾	-20 °C ... +90 °C (-4 °F ... +194 °F)		-20 °C ... +90 °C (-4 °F ... +194 °F)		-20 °C ... +90 °C (-4 °F ... +194 °F)		-20 °C ... +90 °C (-4 °F ... +194 °F)	
Allowable temperature – system ¹⁾	-20 °C ... +90 °C (-4 °F ... +194 °F)		-20 °C ... +90 °C (-4 °F ... +194 °F)		-20 °C ... +90 °C (-4 °F ... +194 °F)		-20 °C ... +90 °C (-4 °F ... +194 °F)	
Cooling capacity – with water cooled heat exchanger (kW) ²⁾	10		10		10		10	
Cooling capacity – with water cooled heat exchanger (kW) ³⁾	3		3		3		3	
Required cooling water quantity (m ³ /h)	0.6		0.6		0.6		0.6	
Cooling capacity – with air cooled heat exchanger (kW) ⁴⁾	2.0		2.0		2.0		2.0	
Cooling capacity – with air cooled heat exchanger (kW) ⁵⁾	1.5		1.5		1.5		1.5	
Metal parts	316L		316L		316L		316L	
Accumulator	CrMo-Stahl		CrMo-Stahl		CrMo-Stahl		CrMo-Stahl	
Bladder	Nitril		Nitril		Nitril		Nitril	

Other versions on request.

¹⁾ Design data, permissible working values depend on the actual conditions of service.

²⁾ Guidelines with barrier fluid water 60 °C (140 °F) – cooling water 20 °C (68 °F).

³⁾ Guidelines with barrier fluid oil 60 °C (140 °F) – cooling water 20 °C (68 °F).

⁴⁾ Guidelines with barrier fluid water 60 °C (140 °F) – ambient temperature 20 °C (68 °F); moved air at min. 0.7 m/s (2.3 ft/s); product flow rate 8 l/min.

⁵⁾ Guidelines with barrier fluid oil 60 °C (140 °F) – ambient temperature 20 °C (68 °F); moved air at min. 0.7 m/s (2.3 ft/s); product flow rate 8 l/min.

^{a)} WEL6002-A4

^{b)} WEF6100-A4

SPO / SPC6 (Plan 53C)



Execution with a water cooler

Features

Pressurized barrier system (closed circuit) for use in seal systems with high pressures and/or for hazardous/ environmentally harmful processes. The SPO Plan 53C range is available with a pressure booster, cooler (finned tube, water or air cooler with fan) and a wide range of instruments.

Circulation in accordance with API 682 / ISO 21049: Plan 53C

Advantages

- Pressurization is by means of a pressure booster
- Automatic setting of the barrier pressure via reference pressure: simple and reliable mode of operation
- Safe operation even in case of pressure changes
- Barrier pressure is created without any need for connection to a nitrogen supply
- Available with finned tube, water or air coolers with fan
- Modular system: combination with a wide range of system components/instruments possible

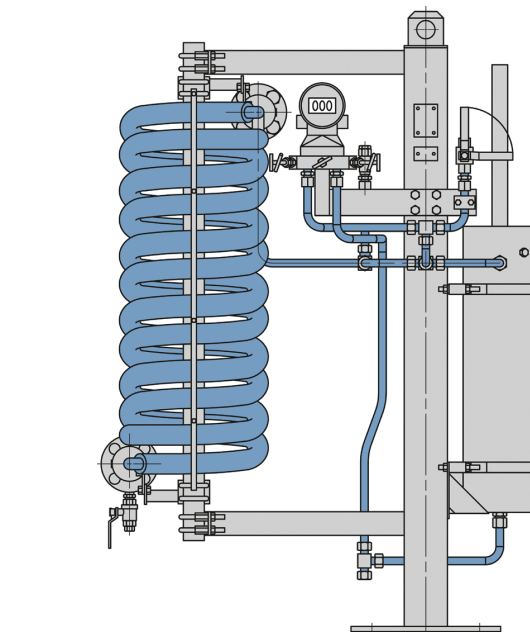

SPC6002-A4 with air cooler

Functional description

The SPO is designed to perform the following functions of a barrier system:

- to pressurize the buffer chamber
- leakage compensation
- to cool the seal

Pressurization (> process pressure) prevents the process medium from getting into the barrier circuit or the atmosphere. Pressurization is supplied by a pressure booster in dependency on the process pressure. Circulation in the barrier circuit takes place by the thermosiphon principle or by forced circulation, e.g. with a pumping screw.

Pressure ratio depending on stuffing box pressure range:

- 4 bar (58 PSI) ... < 10 bar (145 PSI)
= piston ratio 1:1.5
- 10 bar (145 PSI) ... < 22 bar (319 PSI)
= piston ratio 1:1.2
- 22 bar (319 PSI) ... 40 bar (580 PSI)
= piston ratio 1:1.1

For stuffing box pressures less than 4 bar (58 PSI) or above 40 bar (580 PSI) consult EagleBurgmann.

Standards and approvals

- PED 97/23 EC (Design and production in accordance with EU Pressure Equipment Directive)
- ASME VIII, Div. 1 (Design, calculation and production)

Recommended applications

- Petrochemical industry
- Chemical industry
- Oil and gas industry
- Refining technology

Notes

A refilling unit has to be provided.

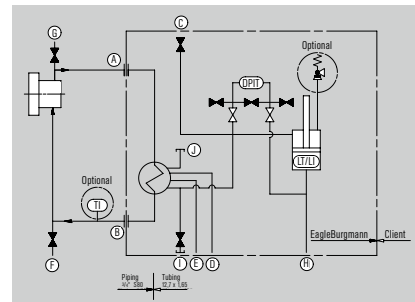

Operating and installation diagram for SPO (Plan 53C)

- A From mechanical seal
- B To mechanical seal
- C Fill
- D Cooling water IN
- E Cooling water OUT
- F Drain
- G Vent
- H Pressure reference
- I Cooling water drain
- J Cooling water vent

Designation	SPC6000-A4		SPC6001-A4		SPC6002-A4		SPC6003-A4	
	ASME		PED		ASME		PED	
Pressure Equipment Directive	ASME		PED		ASME		PED	
Type of heat exchanger	Air cooler ^{a)}	Water cooler ^{a)}	Air cooler ^{a)}	Water cooler ^{a)}	Air cooler ^{a)}	Water cooler ^{a)}	Air cooler ^{a)}	Water cooler ^{a)}
For shaft diameters ≤60 mm (acc. to API 682)	■		■		■		■	
For shaft diameters >60 mm (acc. to API 682)								
Piston Accumulator (liters)	2.8		2.8		5.1		5.1	
Allowable pressure ¹⁾	44 bar (638 PSI)		44 bar (638 PSI)		44 bar (638 PSI)		44 bar (638 PSI)	
Allowable temperature – piston accumulator ¹⁾	-20 °C ... +90 °C (-4 °F ... +194 °F)		-20 °C ... +90 °C (-4 °F ... +194 °F)		-20 °C ... +90 °C (-4 °F ... +194 °F)		-20 °C ... +90 °C (-4 °F ... +194 °F)	
Allowable temperature – system ¹⁾	-20 °C ... +90 °C (-4 °F ... +194 °F)		-20 °C ... +90 °C (-4 °F ... +194 °F)		-20 °C ... +90 °C (-4 °F ... +194 °F)		-20 °C ... +90 °C (-4 °F ... +194 °F)	
Cooling capacity – with water cooled heat exchanger (kW) ²⁾	10		10		10		10	
Cooling capacity – with water cooled heat exchanger (kW) ³⁾	3		3		3		3	
Required cooling water quantity (m ³ /h)	0.6		0.6		0.6		0.6	
Cooling capacity – with air cooled heat exchanger (kW) ⁴⁾	2.0		2.0		2.0		2.0	
Cooling capacity – with air cooled heat exchanger (kW) ⁵⁾	1.5		1.5		1.5		1.5	
Metal parts	316L		316L		316L		316L	

Other versions on request.

¹⁾ Design data, permissible working values depend on the actual conditions of service.

²⁾ Guidelines with barrier fluid water 60 °C (140 °F) – cooling water 20 °C (68 °F).

³⁾ Guidelines with barrier fluid oil 60 °C (140 °F) – cooling water 20 °C (68 °F).

⁴⁾ Guidelines with barrier fluid water 60 °C (140 °F) – ambient temperature 20 °C (68 °F); moved air at min. 0.7 m/s (2.3 ft/s); product flow rate 8 l/min.

⁵⁾ Guidelines with barrier fluid oil 60 °C (140 °F) – ambient temperature 20 °C (68 °F); moved air at min. 0.7 m/s (2.3 ft/s); product flow rate 8 l/min.

^{a)} WEL6002-A4

^{b)} WEF6000-A4

DRU2000



Features

With the EagleBurgmann DRU system it is possible to supply barrier fluid to double and tandem mechanical seals for a broad range of applications. Pressure boosters are equipped as standard with all the necessary system connections and brackets. System components can thus be installed to suit all requirements. The maximum operating pressure of 63 bar applies to the housing of the pressure booster, i. e. the process/medium pressure at the connection must be lower and is conditional on the transmission ratio:

DRU2063/A001 up to 57 bar

DRU2063/A002 up to 42 bar

Circulation in accordance with API 682/ISO 21 049: Plan 53C

Advantages

- Automatic setting of the barrier pressure via reference pressure: simple and reliable mode of operation
- Safe operation even in case of pressure changes
- Barrier pressure is created without any need for connection to a nitrogen supply
- Housing is easy to dismantle: all parts are readily accessible for cleaning
- Protective pipe for piston rod made of borosilicate glass: optimum level monitoring
- Sockets with recessed gasket: no contamination of the circuit by thread sealant
- Modular system: combination with a wide range of system components possible

Functional description

The function of the DRU system is similar in principle to the TS system. The difference is that the barrier pressure is created by the reference pressure without any additional superimposition of nitrogen. The pressure booster is for storing and cooling the barrier fluid. Pressurization is by means of a piston in dependency on the process/medium pressure. Automatic pressure increase in accordance with the transmission ratio.

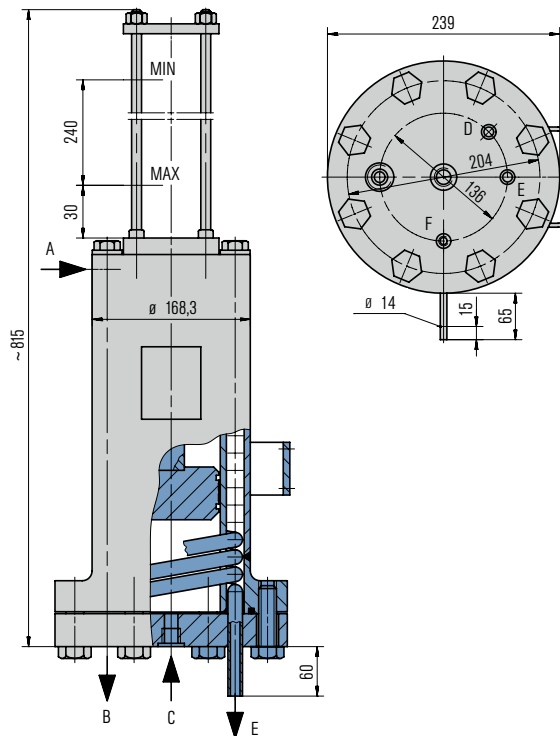

Item Description

- | Item | Description |
|------|--|
| A | Barrier medium IN (G1/2")
connection possible for SPI2063 |
| B | Barrier medium OUT (G1/2") |
| C | Process medium (G1/2") |
| D | Coolant IN (tube 15 x 1.5) |
| E | Coolant OUT (tube 15 x 1.5) |
| F | Connection for SPN (G1/8") |

Standards and approvals

- PED 97/23 EC (Design and production in accordance with EU Pressure Equipment Directive)
- ASME VIII, Div. 1 (Design, calculation and production)

Recommended applications

- Refining technology
- Oil and gas industry
- Chemical industry
- Petrochemical industry

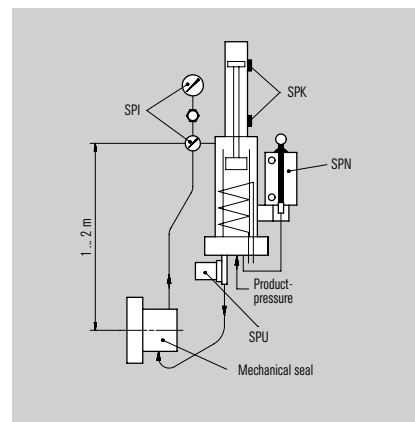

Operating and installation diagram for a DRU system.

The DRU pressure booster must always be installed higher than the mechanical seal. The barrier fluid flows via the return pipe into the vessel and is cooled. The exchange of fluid takes place by the thermosiphon principle or by forced circulation, e. g. with a pumping screw. Connection pipes to the seal should be designed with as little resistance as possible.

Designation	DRU2063/A001	DRU2063/A002	DRU2063/A101	DRU2063/A102
Pressure Equipment Directive	PED	PED	ASME	ASME
Integrated cooling coil	■	■	■	■
Transmission ratio	1:1.1	1:1.5	1:1.1	1:1.5
Volume, jacket (liters)	4	4	4	4
Volume, cooling coil (liters)	0.7	0.7	0.7	0.7
Allowable pressure ¹⁾	63 bar (913 PSI)	63 bar (913 PSI)	63 bar (913 PSI)	63 bar (913 PSI)
Allowable process/medium pressure at connections C ¹⁾	57 bar (827 PSI)	42 bar (609 PSI)	57 bar (827 PSI)	42 bar (609 PSI)
Allowable temperature ¹⁾	-60 °C ... +200 °C (-76 °F ... +392 °F)	-60 °C ... +200 °C (-76 °F ... +392 °F)	-60 °C ... +200 °C (-76 °F ... +392 °F)	-60 °C ... +200 °C (-76 °F ... +392 °F)
Working volume, MAX-MIN (liters)	2	1.5	2	1.5
Cooling capacity – without cooling water (kW) ³⁾	0.5	0.5	0.5	0.5
Cooling capacity – natural circulation (kW) ²⁾	1.5	1.5	1.5	1.5
Cooling capacity – forced circulation (kW) ²⁾	4	4	4	4
Required cooling water quantity (m ³ /h)	0.4	0.4	0.4	0.4
Metal parts	1.4571	1.4571	1.4571	1.4571
Protective tube for piston rod	Borosilicate	Borosilicate	Borosilicate	Borosilicate
Seal	PTFE	PTFE	PTFE	PTFE
Net weight (approx.)	51 kg (112 lb)	51 kg (112 lb)	51 kg (112 lb)	51 kg (112 lb)

Other versions on request.

¹⁾ Design data, permissible working values depend on the actual conditions of service

²⁾ Guidelines with buffer/barrier fluid water 60 °C – cooling water 20 °C

³⁾ Guidelines with barrier fluid water 60 °C – ambient temperature 20 °C (valid for pressure booster systems without cooling water with natural circulation resp. forced circulation)

SPA



Features

Barrier pressure units of the SPA range perform all the functions of a barrier system essential for operating double seals (circulation and cooling of the barrier medium, pressurization of the barrier fluid and compensation of leakage). The SPA range is available in 3 basic versions:

SPA1000: tank capacity 40 l, flow rate 6 l/min.

SPA2000: tank capacity 100 l, flow rate 12 l/min.

SPA3000: tank capacity 100 l, flow rate 23 l/min.

The three SPA ranges are designed for hydraulic oil with viscosity values of 12 to 90 mm²/s at operating temperature (tank temperature). The optimum viscosity of the class of the oil to be used has to be determined separately in accordance with the respective application.

Advantages

- Max. operating temperature in the tank 80 °C (return line max. 90 °C)
- Temperature monitoring with a return line and tank thermometer
- Barrier fluid directed through oil cooler
- Reversible double filter (SPA1000: single filter)
- Manual control of barrier fluid pressure
- Relief valve for reducing barrier fluid pressure at standstill
- Level switch with contact for MIN level
- Measuring instrument connections suitable for fitting contact switching devices (NG160)
- Provision of an additional pressure connection for monitoring the pump discharge pressure (outside the circuit)

Functional description

The barrier pressure for circulation is generated by a gear pump. The setpoint barrier pressure is set on an overflow valve in the mechanical seal return line. From this point on the barrier fluid flows back without pressure through a filter and a heat exchanger to the storage tank. To enable systems (pump, agitator) to be stopped without causing damage to the seal in the event of a malfunction (e.g. power failure, damaged motor, etc.), the barrier pressure unit can be fitted with a pressure accumulator unit. To prevent the pressure in the accumulator discharging to the pressureless storage tank, the return line has a pilot-operated check valve, and the supply line also has a simple check valve. The barrier pressure is retained for a limited time. However, no circulation takes place and no heat is dissipated from mechanical seal.

Materials

- Storage tank, measuring instruments, cooler and piping are made of stainless steel
- Fittings, distributor units, shut-off valves and tank lid are made of galvanized steel

Recommended applications

- Chemical industry
- Petrochemical industry
- Refining technology
- Oil and gas industry

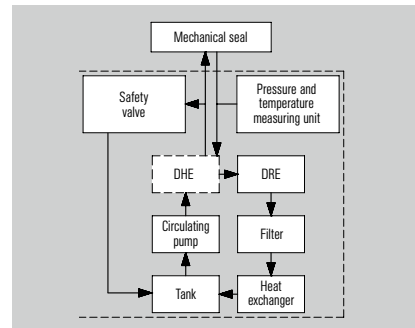

Installation and operating diagram for a SPA system

Product variants

SPA4000 versions for water and other media available as an option.

Version, designation	Nominal pressure, max. barrier pressure	Flow rate (l/min)	Cooling capacity (kW) with hydraulic oil $\Delta t = 10K$	Pressure accumulator DHE	Tank		Dimensions overall (mm)			Net weight (approx.)	Motor data			
					Nominal capacity (liters)	Usable volume (liters)	Height	Width	Depth		Nominal power (kW)	Voltage, frequency	Speed (min ⁻¹)	Ex-Protection
SPA 1015/A01	15 bar (218 PSI)	6	1.8	■	40	12	650	610	380	125 kg (276 lb)	1	400 V 50 Hz	1,500	Atex II 2G Ex e II T3 IP54
SPA 1015/A02	15 bar (218 PSI)	6	1.8	■	40	12	650	610	380	125 kg (276 lb)	1			
SPA 1040/A01	40 bar (580 PSI)	6	1.8	■	40	12	650	610	380	125 kg (276 lb)	1			
SPA 1040/A02	40 bar (580 PSI)	6	1.8	■	40	12	650	610	380	125 kg (276 lb)	1			
SPA 1090/A01	90 bar (1,305 PSI)	6	1.8	■	40	12	650	610	380	125 kg (276 lb)	2			
SPA 1090/A02	90 bar (1,305 PSI)	6	1.8	■	40	12	650	610	380	125 kg (276 lb)	2			
SPA 2020/A01	20 bar (290 PSI)	12	3.6	■	100	20	750	800	555	140 kg (309 lb)	1			
SPA 2020/A02	20 bar (290 PSI)	12	3.6	■	100	20	750	800	555	140 kg (309 lb)	1			
SPA 2050/A01	50 bar (725 PSI)	12	3.6	■	100	20	750	800	555	140 kg (309 lb)	2			
SPA 2050/A02	50 bar (725 PSI)	12	3.6	■	100	20	750	800	555	140 kg (309 lb)	2			
SPA 2120/A01	120 bar (1,740 PSI)	12	3.6	■	100	20	750	800	555	140 kg (309 lb)	3.6			
SPA 2120/A02	120 bar (1,740 PSI)	12	3.6	■	100	20	750	800	555	140 kg (309 lb)	3.6			
SPA 3020/A01	20 bar (290 PSI)	23	6.9	■	100	20	750	800	555	140 kg (309 lb)	2			
SPA 3020/A02	20 bar (290 PSI)	23	6.9	■	100	20	750	800	555	140 kg (309 lb)	2			
SPA 3050/A01	50 bar (725 PSI)	23	6.9	■	100	20	750	800	555	140 kg (309 lb)	3.6			
SPA 3050/A02	50 bar (725 PSI)	23	6.9	■	100	20	750	800	555	140 kg (309 lb)	3.6			
SPA 3120/A01	120 bar (1,740 PSI)	23	6.9	■	100	20	750	800	555	140 kg (309 lb)	6.8			
SPA 3120/A02	120 bar (1,740 PSI)	23	6.9	■	100	20	750	800	555	140 kg (309 lb)	6.8			

DHE Pressure accumulator unit



Features

The DHE consists of an accumulator, a pressure gauge with a shut-off valve and a check valve. The DHE can also be retrofitted to an SPA (Conversion kit No.: DHE140/R001-00).

Advantages

- Suitable for retrofitting to an SPA system (SPA1000, SPA2000, SPA3000)

Functional description

The DHE is used to maintain the barrier fluid pressure for a limited period after the SPA circulating pump has failed or been switched off. It prevents a loss of pressure on the mechanical seal and stops it from opening. The seal, however, is no longer cooled and must therefore be brought to an immediate stop. How long the pressure is maintained will depend on the following two factors: the rate of leakage of the mechanical seal and the amount of buffered fluid stored in the accumulator.

Recommended applications

- Chemical industry
- Petrochemical industry
- Refining technology
- Oil and gas industry

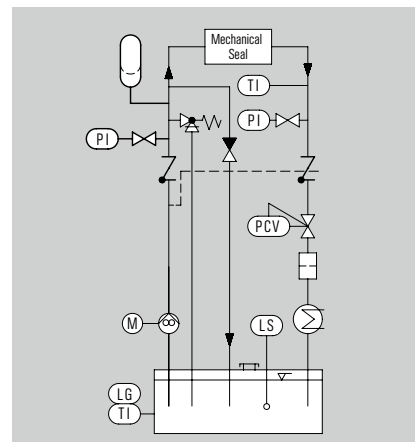

Operating and installation diagram for a SPA system with a **DHE**

DRE Pressure control unit



Features

The pressure control unit is used for setting different levels of barrier pressure when supplying several individual mechanical seals via an SPA with a VTE. There is a choice of 4 basic types.

Advantages

- Suitable for hydraulic oil
- Max. flow rate 23 l/min.
- Max. setting pressure of up to 160 bar

Recommended applications

- Chemical industry
- Petrochemical industry
- Refining technology
- Oil and gas industry

Designation	Max. setting pressure	Max. flow rate (l/min.)	Measuring range
DRE025	25 bar (362 PSI)	23	0 ... 25 bar
DRE050	50 bar (725 PSI)	23	0 ... 60 bar
DRE100	100 bar (1,450 PSI)	23	0 ... 100 bar
DRE160	160 bar (2,320 PSI)	23	0 ... 160 bar

VTE Distribution unit



Features

The distribution unit is used when two or more mechanical seals are to be supplied from a single barrier fluid unit of the SPA1000, SPA2000 or SPA3000 range. The VTE is suitable for hydraulic oil as barrier medium. It is delivered as a separate unit which the customer must install in the pipe work at a suitable position. There is a choice of 2 basic types:

VTE02/M ...: Distribution unit for supplying two or more mechanical seals in between bearing pumps.

VTE .../S ...: Distribution unit for supplying two or more mechanical seals in different pumps. It contains an overflow valve and one flow control valve per seal. DRE pressure control units are necessary if different barrier pressures are used on the mechanical seals.

Advantages

- Distribution unit for supplying several mechanical seals
- Suitable for hydraulic oil

Recommended applications

- Chemical industry
- Petrochemical industry
- Refining technology
- Oil and gas industry

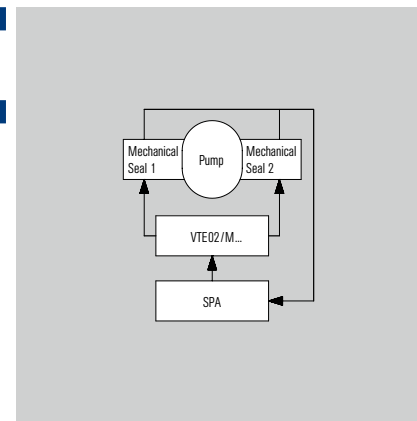

Operating diagram for the **VTE02/M...**

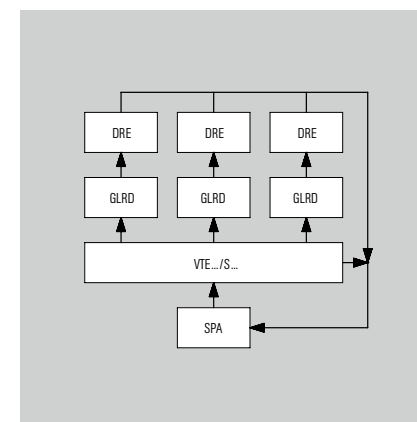

A diagrammatic example for supplying three mechanical seals

Distribution unit for supplying two mechanical seals in between bearing pumps

Designation	Max. barrier pressure	Allowable temperature	Norm. flow/ inlet (l/min.)	Individual current (l/min.)	Allowable viscosity range (mm ² /s)	Suitable for
VTE02/M060	250 bar (3,626 PSI)	-20 °C ... +80 °C (-4 °F ... +176 °F)	6	2 x 3	10 ... 300	SPA1040/A01 (A02) SPA1090/A01 (A02)
VTE02/M120	250 bar (3,626 PSI)	-20 °C ... +80 °C (-4 °F ... +176 °F)	12	2 x 6	10 ... 300	SPA2020/A01 (A02) SPA2050/A01 (A02) SPA2120/A01 (A02)
VTE02/M230	250 bar (3,626 PSI)	-20 °C ... +80 °C (-4 °F ... +176 °F)	23	2 x 11.5	10 ... 300	SPA3020/A01 (A02) SPA3050/A01 (A02) SPA3120/A01 (A02)

Distribution unit for supplying two or more mechanical seals in different pumps

Designation	Max. barrier pressure	Allowable temperature	Norm. flow/ inlet (l/min.)	Individual current (l/min.)	Allowable viscosity range (mm ² /s)	Suitable for	Quantity of supplied mechanical seals
VTE02/S020	210 bar (3,046 PSI)	-20 °C ... +70 °C (-4 °F ... +158 °F)	6	2 x 2.5	2.8 ... 380	SPA1040/A01 (A02) SPA1090/A01 (A02)	2
VTE02/S050	210 bar (3,046 PSI)	-20 °C ... +70 °C (-4 °F ... +158 °F)	12	2 x 5	2.8 ... 380	SPA2020/A01 (A02) SPA2050/A01 (A02) SPA2120/A01 (A02)	2
VTE02/S110	210 bar (3,046 PSI)	-20 °C ... +70 °C (-4 °F ... +158 °F)	23	2 x 11	2.8 ... 380	SPA3020/A01 (A02) SPA3050/A01 (A02) SPA3120/A01 (A02)	2
VTE03/S030	210 bar (3,046 PSI)	-20 °C ... +70 °C (-4 °F ... +158 °F)	12	3 x 3.5	2.8 ... 380	SPA2020/A01 (A02) SPA2050/A01 (A02) SPA2120/A01 (A02)	3
VTE03/S072	210 bar (3,046 PSI)	-20 °C ... +70 °C (-4 °F ... +158 °F)	23	3 x 7	2.8 ... 380	SPA3020/A01 (A02) SPA3050/A01 (A02) SPA3120/A01 (A02)	3
VTE04/S021	210 bar (3,046 PSI)	-20 °C ... +70 °C (-4 °F ... +158 °F)	12	4 x 2.5	2.8 ... 380	SPA2020/A01 (A02) SPA2050/A01 (A02) SPA2120/A01 (A02)	4
VTE04/S052	210 bar (3,046 PSI)	-20 °C ... +70 °C (-4 °F ... +158 °F)	23	4 x 5	2.8 ... 380	SPA3020/A01 (A02) SPA3050/A01 (A02) SPA3120/A01 (A02)	4

Versions for supplying more than four mechanical seals on request.

SPN



Features

The SPN is used as an automatic refill unit and for barrier fluid pressurization in seal circuits. It is possible to use pneumatic or electric power, or a combination of both for the pressurization. The refill unit tank is designed for pressureless operation and is equipped with a level switch and a sight-glass (automatic refill unit also available as an option). The refill unit has all pipework as far as the distributor unit. Separate components are installed in the seal circuit to cool and to circulate the barrier medium. The SPN range is available in 2 basic versions:

- SPN1000:** Vessel capacity 20 or 40 liters
- SPN3000:** Vessel capacity 40, 60 or 200 liters

Barrier fluid pressure regulation for the SPN1000 via pressure switch to the pump control.

The SPN3000 is equipped with a pressure regulator for maintaining a constant barrier pressure level.

Advantages

- Reliable mode of operation: should the pump be switched off, the barrier fluid pressure will be maintained for a limited time by an integrated accumulator
- Membrane accumulator acts as a pulsation damper/ barrier fluid storage tank
- SPN3000: maintains constant barrier pressure irrespective of hysteresis-induced pressure fluctuations of the pressure switch
- Visual level indicator via sight-glass on the vessel

Functional description

SPN automatic refill units differ from an SPA in that they perform just two of the four basic functions of a barrier fluid system, namely barrier fluid pressurization and leakage compensation. It is possible to use a piston pump with either electric or pneumatic power for pressurization of the barrier medium. Should all the pumps fail, the pressure will be maintained in the refill unit for a limited time to ensure that pressurization of the barrier fluid circuit is maintained. How long the pressure is maintained will depend on the storage volume and the leakage losses to be compensated.

Materials

Parts in contact with the medium are made of stainless steel. Secondary seals and elastomers are resistant to water, demineralized water and hydraulic oil.

Recommended applications

- Chemical industry
- Petrochemical industry
- Oil and gas industry
- Refining technology

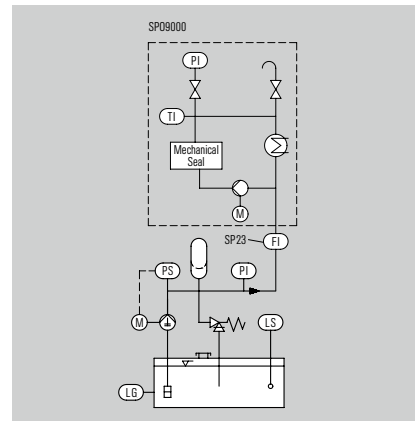

Operating and installation diagram for an automatic refill unit.

Product variants

The **SPN automatic refill unit** can be supplied with a wide range of system components and engineered systems to meet specific customer requirements.

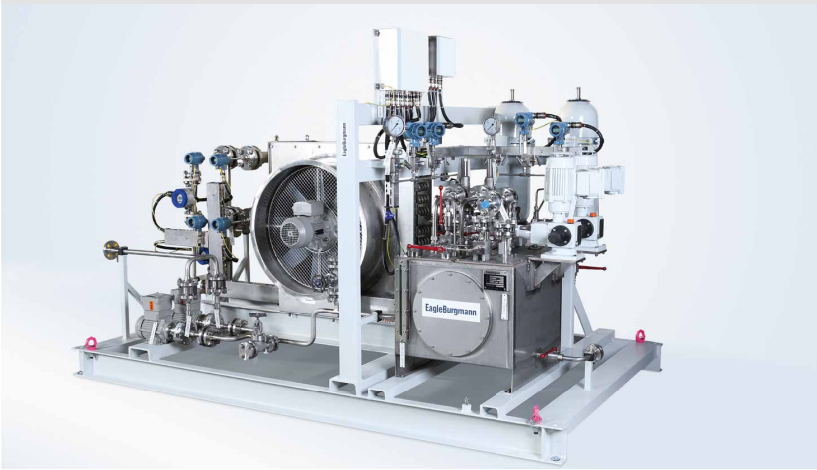

Designation	Barrier fluid pressure adjustable from ... to	Max. flow rate (l/h)	Vessel volume (liters)	Number of pumps	Type of drive	Nominal output (kW)	Max air rate (Nm ³ /h)	Approx. overall dimensions in cm H x W x B	Net weight (approx.)
SPN1020/EO02	0.5 ... 20 bar (7.25 ... 290 PSI)	10	20	1	E	0.18	-	69 x 37 x 36	40 kg (88 lb)
SPN1020/LO02	5 ... 20 bar (73 ... 290 PSI)	60	20	1	L	-	26	58 x 37 x 36	30 kg (66 lb)
SPN1063/EO02	5 ... 63 bar (73 ... 914 PSI)	10	20	1	E	0.18	-	69 x 37 x 36	40 kg (88 lb)
SPN1063/LO02	20 ... 63 bar (290 ... 914 PSI)	60	20	1	L	-	26	58 x 37 x 36	30 kg (66 lb)
SPN1063/EO04	5 ... 63 bar (73 ... 914 PSI)	10	40	1	E	0.18	-	69 x 69 x 36	50 kg (110 lb)
SPN1063/LO04	20 ... 63 bar (290 ... 914 PSI)	60	40	1	L	-	26	58 x 69 x 36	40 kg (88 lb)
SPN1063/EO04	5 ... 63 bar (73 ... 914 PSI)	20	40	2	E	2 x 0.18	-	69 x 69 x 36	60 kg (132 lb)
SPN1063/LL04	20 ... 63 bar (290 ... 914 PSI)	120	40	2	L	-	52	58 x 69 x 36	50 kg (110 lb)
SPN1063/EL04	20 ... 63 bar (290 ... 914 PSI)	70	40	2	EL	0.18	26	69 x 69 x 36	60 kg (132 lb)
SPN3035/EO04	4 ... 35 bar (58 ... 508 PSI)	10	40	1	E	0.18	-	69 x 69 x 36	70 kg (154 lb)
SPN3035/LO04	4 ... 35 bar (58 ... 508 PSI)	60	40	1	L	-	30	58 x 69 x 36	60 kg (132 lb)
SPN3035/EL06	4 ... 35 bar (58 ... 508 PSI)	70	60	2	EL	0.18	30	69 x 100 x 37	80 kg (176 lb)
SPN3035/EE06	4 ... 35 bar (58 ... 508 PSI)	20	60	2	EE	2 x 0.18	-	69 x 100 x 37	80 kg (176 lb)
SPN3035/LL06	4 ... 35 bar (58 ... 508 PSI)	120	60	2	LL	-	60	58 x 100 x 37	70 kg (154 lb)
SPN3063/EO20	0 ... 63 bar (0 ... 914 PSI)	130	200	1	E	1.1	-	110 x 175 x 100	120 kg (265 lb)
SPN3063/LO20	0 ... 63 bar (0 ... 914 PSI)	300	200	1	L	-	175	100 x 130 x 70	300 kg (661 lb)
SPN3063/EL20	0 ... 63 bar (0 ... 914 PSI)	430	200	2	EL	1.1	175	110 x 175 x 100	450 kg (992 lb)
SPN3063/EE20	0 ... 63 bar (0 ... 914 PSI)	260	200	2	EE	2 x 1.1	-	110 x 175 x 100	500 kg (1,102 lb)
SPN3063/LL20	0 ... 63 bar (0 ... 914 PSI)	600	200	2	LL	-	350	100 x 130 x 170	400 kg (882 lb)
SPN3120/EO20	0 ... 120 bar (0 ... 1,740 PSI)	130	200	1	E	2.5	-	110 x 175 x 100	450 kg (992 lb)
SPN3120/LO20	0 ... 120 bar (0 ... 1,740 PSI)	300	200	1	L	-	175	100 x 130 x 70	300 kg (661 lb)
SPN3120/EL20	0 ... 120 bar (0 ... 1,740 PSI)	430	200	2	EL	2.5	175	110 x 175 x 100	480 kg (1,058 lb)
SPN3120/EE20	0 ... 120 bar (0 ... 1,740 PSI)	260	200	2	EE	2 x 2.5	-	110 x 175 x 100	500 kg (1,102 lb)
SPN3120/LL20	0 ... 120 bar (0 ... 1,740 PSI)	600	200	2	L	-	350	100 x 130 x 70	400 kg (882 lb)

Other versions on request.

General features:

All connecting threads G1/2"

Type of protection: Ex e II T3

SPN



SPN4016

Features

The hand refill pump (shown above: SPN4016) consists of a storage vessel with level indicator, filling filter and a hand pump with integrated check valve. It is mounted directly on the thermosiphon vessel or pressure booster. There are a choice of 2 basic types in the SPN range of products:

SPN2000: Stainless steel hand refill pump for universal applications

SPN4000: specifically for use with TS1016 systems (picture: SPN4016)

Advantages

- For efficient processes, with a choice of 2 basic types
- For manual refilling of barrier fluid units during operation
- SPN4016 vessel made of polyethylene: suitable for use in potentially explosive environments
- SPN2000 in stainless steel and acrylic or borosilicate sight-glasses: suitable for highly corrosive media
- Two sight-glasses for reading the MIN/MAX fluid level
- Reliable mode of operation: Combined filling and ventilation filter in the hand refill pump

Functional description

The hand refill pump is designed for manual refilling during operation in case of barrier fluid losses.

Recommended applications

- Chemical industry
- Petrochemical industry
- Oil and gas industry
- Refining technology
- Pulp and paper industry
- Food and beverage industry

Product variant

SPN2063



Designation	Volume (liters)	Allowable temperature	Material, vessel		Material sight-glass/Seal		Material, filling filter		Pressure control valve			
			Stainless steel	Polyethylene	Acrylic glass, Perbunan®	Borosilicate, T2	Polyamide	Stainless steel	None	16 bar (232 PSI)	30 bar (435 PSI)	63 bar (913 PSI)
SPN2030	2	60 °C (140 °F)	■		■		■				■	
SPN2063	2	60 °C (140 °F)	■		■		■		■			
SPN2063/A015	2	60 °C (140 °F)	■		■		■					■
SPN2063/A100	2	60 °C (140 °F)	■			■	■		■			
SPN2063/A200	2	60 °C (140 °F)	■			■	■	■				
SPN4016	2	60 °C (140 °F)		■	■		■			■		

WDK



Features

WDK5120 heat exchangers are used to cool process/barrier fluids in seal supply circuits. The heat exchanger has a wound double helix around the guide tube. Process/barrier medium in the tubes, cooling medium around the tubes.

Circulation in accordance with API 682/ISO 21 049: Plan 21, Plan 22, Plan 23, Plan 41

Advantages

- Effective cooling: with wound double helix around a guide tube
- Cooling capacity up to 10.5 kW
- Excellent value for money
- Vessel can be dismantled: for optimum cleaning of the cooling water side
- Universal usage: parts in contact with the buffer medium are made of 1.4571

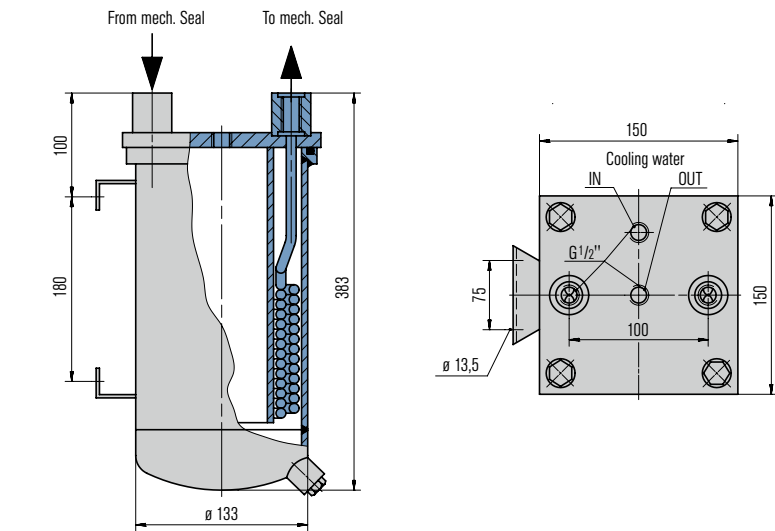

Standards and approvals

- PED 97/23 EC (Design and production in accordance with EU Pressure Equipment Directive)

Recommended applications

- Chemical industry
- Petrochemical industry
- Power plant technology
- Refining technology
- Oil and gas industry

Notes

Cleaning:

Cooling water side: the area around the tubes can be cleaned mechanically after the housing is removed.
Process/barrier medium side: flush with a suitable solvent.

Designation	WDK5120/A003	
	Tube	Shell
Pressure Equipment Directive		PED
Allowable pressure ¹⁾	120 bar (1,740 PSI)	16 bar (232 PSI)
Allowable temperature ¹⁾	160 °C (320 °F)	95 °C (203 °F)
Inlet temperature ²⁾	70 °C (158 °F)	25 °C (77 °F)
Flow rate ²⁾	0.6 m ³ /h	1.8 m ³ /h
Volume	0.5 liters	3.5 liters
Cooling surface ²⁾		0.3 m ²
Cooling capacity		10.5 kW
Net weight (approx.)		10.3 kg (23 lb)
Full weight (approx.)		14.3 kg (32 lb)
Metal parts	1.4571	Carbon steel, primed on the outside
Seals		Viton®
Screws		Stainless steel A4-70

Other versions on request.

¹⁾ These values are based on the calculation of strength.

²⁾ These values are based on the calculation of heat.

WED

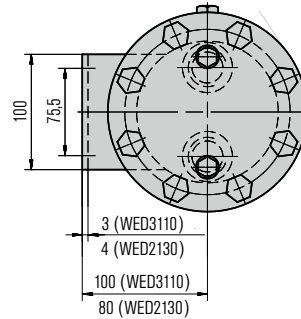
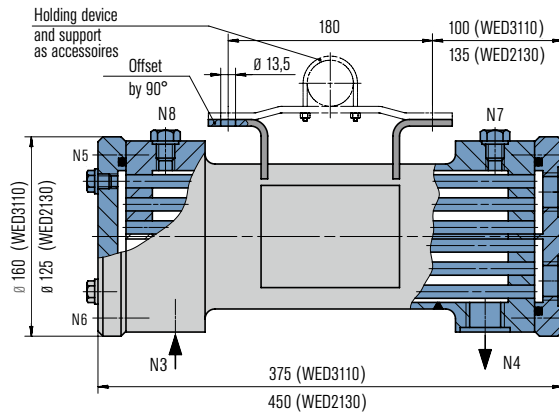

Features

Heat exchangers of the WED range are used to cool process/barrier fluids in seal supply circuits. Designed as a tubular heat exchanger with integrated guide plates, the buffer medium is directed through the shell of the WED and the cooling medium through the tubes.

Circulation in accordance with API 682/ISO 21 049: Plan 21, Plan 22, Plan 23, Plan 41

Advantages

- Tubular heat exchanger design with integrated guide plates: extremely efficient cooling capacity yet very compact dimensions
- Cooling capacity up to 36 kW*
- Universal usage: parts in contact with the medium are made of 1.4571
- It can be installed either in vertical or horizontal position
- The heat exchanger can be dismantled: easy to clean

Standards and approvals

- PED 97/23 EC (Design and production in accordance with EU Pressure Equipment Directive)
- ASME VIII, Div. 1 (Design, calculation and production)

Recommended applications

- Chemical industry
- Petrochemical industry
- Oil and gas industry
- Refining technology
- Power plant technology

Notes

Cleaning:
Cooling water side: it can be cleaned mechanically after the cover is removed.
Process/barrier medium side: flush with a suitable solvent.

Item Description

- Connections
- N2 Cooling water OUT
 - N1 Cooling water IN
 - N4 Process/barrier medium OUT
 - N3 Process/barrier medium IN
 - N7/N8 Process/barrier circuit vent
 - N5 Cooling circuit vent
 - N6 Cooling water drain

Product variant

WED1050



Designation	WED1050/A001-D0		WED2130/A100		WED3110/A100		WED3050/A001-00	
	Tubes	Shell	Tubes	Shell	Tubes	Shell	Tubes	Shell
Pressure Equipment Directive	PED 97/23 EC art. 3 clause (3)		PED		PED		PED	
Allowable pressure ¹⁾	16 bar (232 PSI)	50 bar (725 PSI)	25 bar (232 PSI)	363 bar (1,885 PSI)	25 bar (363 PSI)	110 bar (1,595 PSI)	16 bar (232 PSI)	50 bar (725 PSI)
Allowable temperature ¹⁾	95 °C (203 °F)		150 °C (302 °F)		150 °C (302 °F)		300 °C (572 °F)	
Inlet temperature ²⁾	40 °C (104 °F)	65 °C (149 °F)	30 °C (86 °F)	65 °C (149 °F)	30 °C (86 °F)	65 °C (149 °F)	30 °C (86 °F)	65 °C (149 °F)
Flow rate (m ³ /h) ²⁾	2.2	1.8	1	approx. 0.5	6	approx. 3	6	approx. 3
Volume (liters)	0.83	1.62	0.23	1.4	0.75	1.8	0.75	1.8
Cooling surface (m ²) ²⁾	0.6		0.2		0.6		0.6	
Cooling capacity (kW) ²⁾	20		6		36		36	
Net weight (approx.)	13 kg (29 lb)		14 kg (31 lb)		24 kg (53 lb)		24 kg (53 lb)	
Metal parts	1.4404	1.4571	1.4571		1.4571		1.4571	
O-Rings	---		Viton®		Viton®		Viton®	
Gaskets	Aramid fibres, NBR bound		PTFE		PTFE		PTFE	
Screws	1.4301 / A2-70		Stainless steel A4-70		Stainless steel A4-70		Stainless steel A4-70	

Other versions on request.

¹⁾ These values are based on the calculation of strength.

²⁾ These values are based on the calculation of heat.

³⁾ With reference to water

WEF6

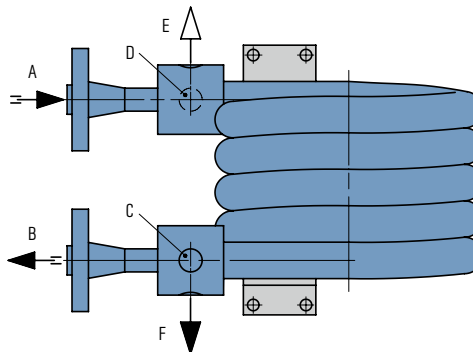

Features

Heat exchangers of the WEF6000-A4 range are used to cool process/barrier fluids in seal supply circuits. WEF6000-A4 heat exchangers are fully compliant with API 682 4th edition regulations. The process/barrier medium is directed through the tube, and the cooling medium is directed through the shell. Venting and draining of the process/barrier medium side as well as the cooling water side is ensured. In addition, the heat exchangers can also be combined with a temperature instrument in the supply line To mechanical seal (optional in accordance with API 682 4th edition).

Advantages

- Operating limits up to 45 bar / 260 °C (653 PSI / 500 °F) (tube side): suitable for a wide range of operations
- Cooling water and process side can be completely vented and drained
- Seamless pipes on process side
- Special design without welding inside the cooler
- Higher cooling water velocity due to innovative cooler design
- Stainless steel 316L: high resistance to corrosive media

Recommended applications

- Refining technology
- Oil and gas industry
- Petrochemical industry
- Chemical industry
- Power plant technology

Item Description

- A From mechanical seal
- B To mechanical seal
- C Cooling water IN
- D Cooling water OUT
- E Vent
- F Drain

Notes

Design and production in accordance with EU Pressure Equipment Directive PED 97/23 EC. Design, calculation and production acc. to ASME VIII, Div. 1 (cooler not subject to ASME stamp requirements, piping <6")

Cleaning:

Process/barrier medium side and cooling water side: flush with a suitable solvent.

Designation	WEF6100-A4		WEF6100-A4		WEF6000-A4		WEF6000-A4	
	Tubes	Shell	Tubes	Shell	Tubes	Shell	Tubes	Shell
Type of heat exchanger	ASME		PED		ASME		PED	
Process connections	Flange 3/4", 600 lbs	NPT 3/4"	Flange 3/4", 600 lbs	NPT 3/4"	Flange 3/4", 600 lbs	Flange 3/4", 300 lbs	Flange 3/4", 600 lbs	Flange 3/4", 300 lbs
Drain / vent connection		NPT 1/2"		NPT 1/2"		NPT 1/2"		NPT 1/2"
Allowable pressure ¹⁾	45 bar (653 PSI)	16 bar (232 PSI)	45 bar (653 PSI)	16 bar (232 PSI)	45 bar (653 PSI)	16 bar (232 PSI)	45 bar (653 PSI)	16 bar (232 PSI)
Allowable temperature cooling water side (shell side) ¹⁾	-29 °C ... +150 °C (-20 °F ... +302 °F)		-29 °C ... +150 °C (-20 °F ... +302 °F)		-29 °C ... +150 °C (-20 °F ... +302 °F)		-29 °C ... +150 °C (-20 °F ... +302 °F)	
Allowable temperature process/barrier medium side (tube side) ¹⁾	-29 °C ... +260 °C (-20 °F ... +500 °F)		-29 °C ... +260 °C (-20 °F ... +500 °F)		-29 °C ... +260 °C (-20 °F ... +500 °F)		-29 °C ... +260 °C (-20 °F ... +500 °F)	
Cooling capacity (kW) ²⁾	10		10		10		10	
Cooling capacity (kW) ³⁾	3		3		3		3	
Required cooling water quantity (m ³ /h)	0.6		0.6		0.6		0.6	
Metal parts	316L		316L		316L		316L	

Other versions on request.

¹⁾ Design data, permissible working values depend on the actual conditions of service

²⁾ Guidelines with barrier/buffer fluid water 60 °C (140 °F) – cooling water 20 °C (68 °F).

³⁾ Guidelines with barrier/buffer fluid oil 60 °C (140 °F) – cooling water 20 °C (68 °F).

WE

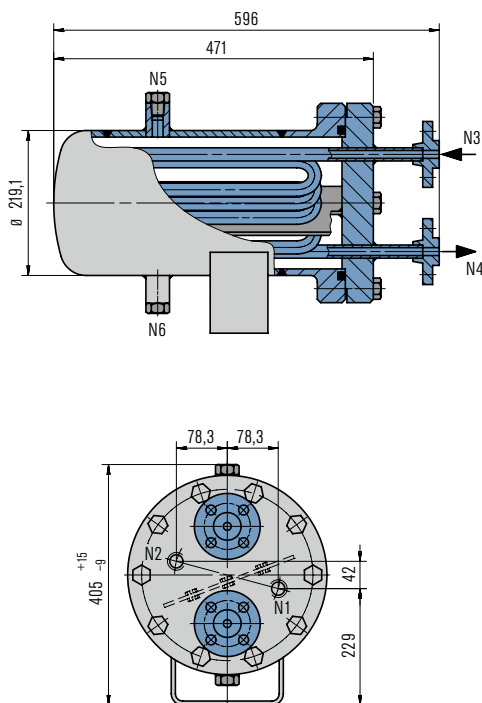

Features

Heat exchangers of the WE range are used to cool process/barrier fluids in seal supply circuits. WE heat exchangers are available in two standard sizes and are API 682 conform. The process/barrier medium is directed through the tube and the cooling medium through the shell.

For simple draining or venting of the cooling water side, the heat exchanger can also be supplied with ventilation/drainage ball valves. In addition, the heat exchangers can also be combined with a temperature instrument in the supply line To mechanical seal (optional in accordance with API 682).

Circulation in accordance with API 682/ISO 21 049: Plan 21, Plan 22, Plan 23, Plan 41

Advantages

- Operating limits up to 45 bar/260 °C (tube side): suitable for a wide range of demanding operating conditions.
- Heat exchanger can be dismantled: for optimum and simple cleaning of the tubes
- Cooling water side and process side can be completely vented and drained
- 1.4404 stainless steel: high resistance to corrosive media

Standards and approvals

- PED 97/23 EC (Design and production in accordance with EU Pressure Equipment Directive)
- ASME VIII, Div. 1 (Design, calculation and production)

Recommended applications

- Chemical industry
- Petrochemical industry
- Oil and gas industry
- Refining technology

Notes

Cleaning:
Cooling water side: the area around the tubes can be cleaned mechanically after the housing is removed.
Process/barrier medium side: flush with a suitable solvent.

Designation	WE6045/A002		WE6045/A001		WE6045/M014-D0		WE6045/M015-D0		WE6045/M016-D0		WE6045/M017-D0	
	Tubes	Shell	Tubes	Shell	Tubes	Shell	Tubes	Shell	Tubes	Shell	Tubes	Shell
Pressure Equipment Directive For shaft diameters ≤60 mm (acc. to API 682)	ASME		ASME		ASME		ASME		ASME		ASME	
For shaft diameters >60 mm (acc. to API 682)	■		■		■		■		■		■	
Ball valve for draining on the cooling water side	■		■		■		■		■		■	
Process connections	Flange 1/2"	1/2 NPT	Flange 3/4"	3/4 NPT	Flange 1/2"	1/2 NPT	Flange 3/4"	3/4 NPT	1/2 NPT	1/2 NPT	3/4 NPT	3/4 NPT
Design pressure ¹⁾	45 bar (653 PSI)	16 bar (232 PSI)	45 bar (653 PSI)	16 bar (232 PSI)	45 bar (653 PSI)	16 bar (232 PSI)	45 bar (653 PSI)	16 bar (232 PSI)	45 bar (653 PSI)	16 bar (232 PSI)	45 bar (653 PSI)	16 bar (232 PSI)
Design temperature ¹⁾	260 °C (500 °F)	150 °C (302 °F)	260 °C (500 °F)	150 °C (302 °F)	260 °C (500 °F)	150 °C (302 °F)	260 °C (500 °F)	150 °C (302 °F)	260 °C (500 °F)	150 °C (302 °F)	260 °C (500 °F)	150 °C (302 °F)
Cooling capacity (kW) ²⁾	4		6		4		6		4		6	
Metal parts	1.4404		1.4404		1.4404		1.4404		1.4404		1.4404	
O-Rings	Viton®		Viton®		Viton®		Viton®		Viton®		Viton®	
Screws	Stainless steel A4-70		Stainless steel A4-70		Stainless steel A4-70		Stainless steel A4-70		Stainless steel A4-70		Stainless steel A4-70	

Other versions on request.

¹⁾ These values are based on the calculation of strength.

²⁾ Related to water on both sides

WEL1000

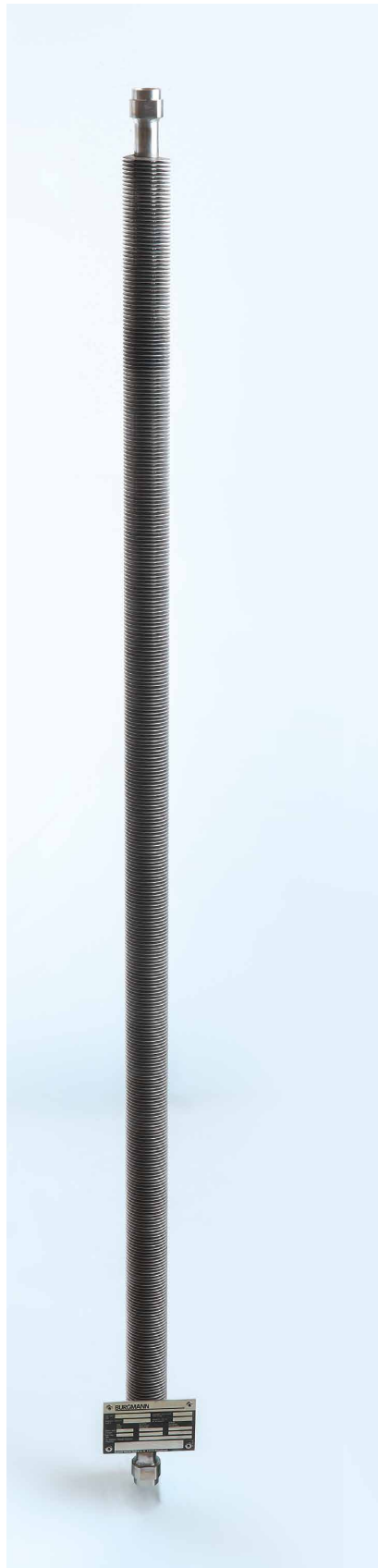

Features

Heat exchangers of the WEL1000 range are used to cool process/barrier fluids in seal supply circuits. The heat exchangers are made of straight, laser-welded finned tubes. The cooling medium is ambient air. It is important, therefore, for WEL heat exchangers to be installed in well ventilated places indoors or, ideally, outdoors. There is a choice of two different basic versions of the WEL1000 range (1 or 2 tubes), supplied fully assembled along with valves, base frame and other system components.

Circulation in accordance with API 682/ISO 21 049: Plan 21, Plan 22, Plan 23, Plan 41

Advantages

- Welded finned tubes without gaps for guaranteed optimum energy transmission
- Universal usage: high-quality 1.4571 stainless steel finned tube design
- No cooling water connection or heating required for the cooling water pipe in winter
- There is a choice of two different basic versions

Standards and approvals

- PED 97/23 EC (Design and production in accordance with EU Pressure Equipment Directive)
- ASME VIII, Div. 1 (Calculation)

Recommended applications

- Chemical industry
- Petrochemical industry
- Oil and gas industry
- Refining technology
- Power plant technology

Notes

WEL heat exchangers should be installed in well ventilated places indoors or, ideally, outdoors. Vertical installation is essential.

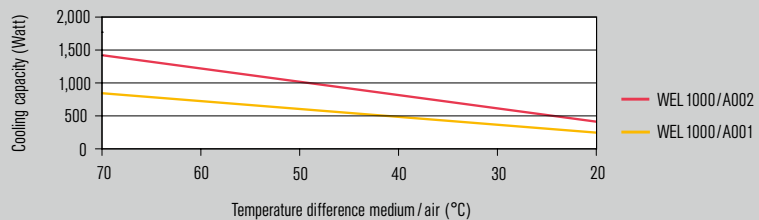

Cooling capacity: Values based on moved air min. 0.7 m/s and barrier fluid water.

Designation	WEL1000/A001	WEL1000/A002
Pressure Equipment Directive	PED	PED
Number of finned tubes	1	2
Process connections	G1/2"	G1/2"
Allowable pressure ¹⁾	110 bar (1,595 PSI)	110 bar (1,595 PSI)
Allowable temperature ¹⁾	200 °C (392 °F)	200 °C (392 °F)
Volume (liters)	0.7	1.4
Parts in contact with the medium	1.4571	1.4571

Other versions on request.

¹⁾ These values are based on the calculation of strength.

WEL2000



Features

Heat exchangers of the WEL2000 range (shown above: WEL2001/A040) are used to cool process/barrier fluids in seal supply circuits. The heat exchangers are made of helical, laser-welded finned tubes. The cooling medium is ambient air. It is important, therefore, for WEL heat exchangers to be installed in well ventilated places indoors or, ideally, outdoors. There is a choice of three different basic versions of the WEL2000 range, supplied fully assembled along with valves, base frame and other system components.

Circulation in accordance with API 682/ISO 21 049: Plan 21, Plan 22, Plan 23, Plan 41

Advantages

- Helical finned tube design with vertical arrangement of the fins to the wind direction: the solution for high cooling capacities
- Welded finned tubes without gaps for guaranteed optimum energy transmission
- Universal usage: high-quality 1.4571 stainless steel finned tube design
- No cooling water connection or heating required for the cooling water pipe in winter
- There is a choice of three different basic versions

Standards and approvals

- PED 97/23 EC (Design and production in accordance with EU Pressure Equipment Directive)
- ASME VIII, Div. 1 (Calculation)

Recommended applications

- Chemical industry
- Petrochemical industry
- Oil and gas industry
- Refining technology
- Power plant technology

Notes

WEL heat exchangers should be installed in well ventilated places indoors or, ideally, outdoors. Vertical installation is essential.

Product variants

WEL6002A4A100-DO according to API 682 4th edition. Two finned tubes switched on parallel.

WEL2002/A003 2 finned tubes switched in parallel and double length.

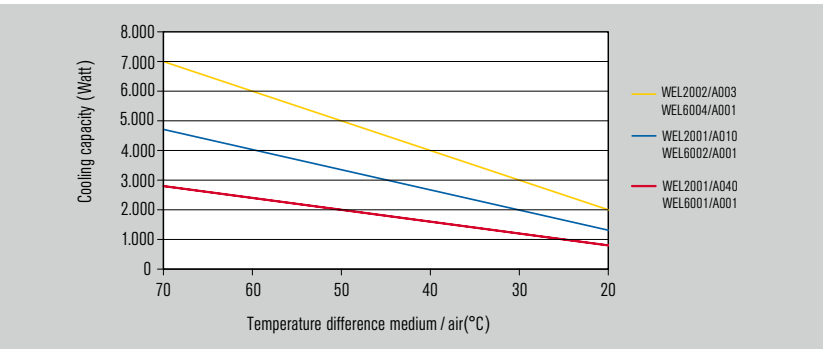

Cooling capacity: Values based on moved air min. 0.7 m/s and barrier fluid water.

Designation	WEL2001/A040	WEL2001/A010	WEL2002/A003	WEL6001A4A001-DO	WEL6002A4A001-DO	WEL6004A4A001-DO
API682 4th edition conformity						
Pressure Equipment Directive	PED	PED	PED	ASME VIII, Div. 1	ASME VIII, Div. 1	ASME VIII, Div. 1
Number of finned tubes	1	2 finned tubes switched in parallel	2 finned tubes switched in parallel, double length	1	2 finned tubes switched in parallel	2 finned tubes switched in parallel, double length
Process connections	G1/2"	G1/2"	G1/2"	Flange 3/4", 600 lbs	Flange 3/4", 600 lbs	Flange 3/4", 600 lbs
Drain / Vent	G1/2"	G1/2"	G1/2"	Flange 1/2", 600 lbs ²⁾	Flange 1/2", 600 lbs ²⁾	Flange 1/2", 600 lbs ²⁾
Allowable pressure ¹⁾	110 bar (1,595 PSI)	110 bar (1,595 PSI)	110 bar (1,595 PSI)	44 bar (638 PSI)	44 bar (638 PSI)	44 bar (638 PSI)
Allowable temperature ¹⁾	200 °C (392 °F)	200 °C (392 °F)	200 °C (392 °F)	-29 ... +260 °C (-20 °F ... +500 °F)	-29 ... +260 °C (-20 °F ... +500 °F)	-29 ... +260 °C (-20 °F ... +500 °F)
Volume (liters)	1.7	3.4	6.8	1.2	2.4	4.8
Parts in contact with the medium	1.4571	1.4571	1.4571	316L	316L	316L

Other versions on request.

¹⁾ These values are based on the calculation of strength.

²⁾ Version with screwed connection G1/2" available as an option.

SPX6 (Plan 32)

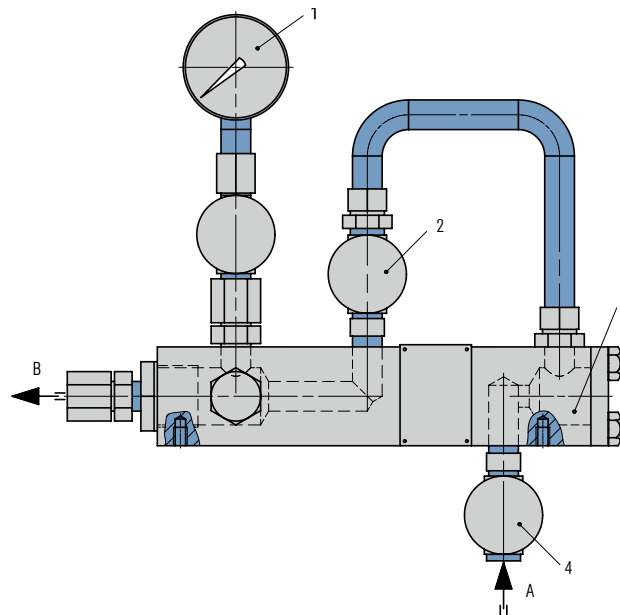

Features

The EagleBurgmann flush unit of the SPX6000-A4 range consist of a manifold with integrated inline filter supplied together with a needle valve and pressure gauge. Optional available with temperature gauge and/or flow indicator. The unit is used to control the flushing of a mechanical seal.

Circulation in accordance with API 682 4th edition: Plan 32

Advantages

- Compact design due to integral filter
- Modular concept - optional monitoring equipment available

Functional description

The SPX6000-A4 flush unit continuously supplies flushing media from an external source To mechanical seal. This plan is almost always used in combination with a throat bushing which serves as a throttle device to maintain a higher pressure in the stuffing box to isolate the pumped product from the seal chamber.

Recommended applications

- Refining technology
- Oil and gas industry
- Petrochemical industry
- Chemical industry
- Power plant technology

Item Description

1	Pressure indicator
2	Needle valve
3	Integral filter
4	Valve
A	From external source
B	To mechanical seal

Designation	SPX6000-A4
Allowable pressure ¹⁾	44 bar (638 PSI)
Allowable temperature ¹⁾	-20 °C ... +120 °C (-4 °F ... +248 °F)
Process connections	1/2" NPT
Metal parts	316L

Other versions on request.

¹⁾ Design data, permissible working values depend on the actual conditions of service

LS050 / LSA6 / LSB6 (Plan 65)



LS050 (Plan 65, API 682 3rd edition)

Features

The EagleBurgmann leakage control systems of the LS050 range in accordance with API Plan 65 consist of a leakage collection tank with integrated orifice and overflow pipe along with two shut-off valves. The level can be monitored with the a level switch.

Circulation in accordance with API 682/ISO 21 049:
Plan 65

Advantages

- Innovative design: orifice and overflow pipe integrated in the vessel
- No need for extra pipe work for the overflow pipe
- Low space requirements because of compact design
- Integrated level monitoring for reliable operation

Functional description

The LS050 leakage control system in accordance with API Plan 65 is used to discharge leakage from single seals. The outboard leakage is collected in an external tank; the leakage volume is monitored (level in the tank).

Standards and approvals

- PED 97/23 EC (Design and production in accordance with EU Pressure Equipment Directive)
- ASME VIII, Div. 1 (Design, calculation and production)

Recommended applications

- Refining technology
- Oil and gas industry
- Chemical industry
- Petrochemical industry

Designation	LS050/M004-D0	LS050/M006-D0	LSA6000-A4	LSB6000-A4
Pressure Equipment Directive	PED	PED	PED / ASME	PED / ASME
Volume, vessel (liters)	3	3	4	4
Allowable pressure ¹⁾	50 bar (725 PSI)	50 bar (725 PSI)	44 bar (638 PSI)	44 bar (638 PSI)
Allowable temperature ¹⁾	0 °C ... +80 °C (32 °F ... +176 °F)	0 °C ... +80 °C (32 °F ... +176 °F)	-20 °C ... +120 °C (-4 °F ... +248 °F)	-20 °C ... +120 °C (-4 °F ... +248 °F)
Metal parts	1.4571	1.4571	316L	316L
Process connections	1/2 NPT	Flange 1/2"	Flange 3/4", 600 lbs	Flange 3/4", 600 lbs
Level monitoring	LSH	LSH	DPIT	DPIT
API682 3rd edition	Plan 65	Plan 65		
API682 4th edition			Plan 65A	Plan 65B

Other versions on request.

¹⁾ Design data, permissible working values depend on the actual conditions of service.

Product variants

According to API 682 4th edition

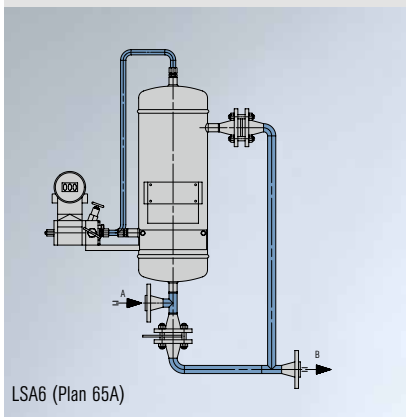

LSA6 (Plan 65A)

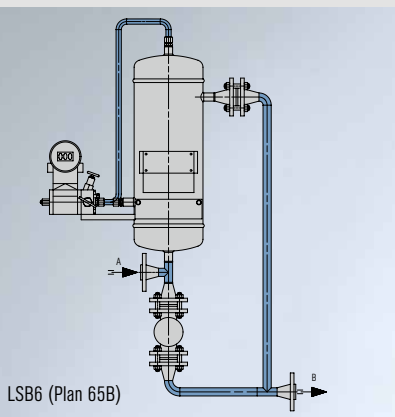

LSB6 (Plan 65B)

SPP6 (Plan 66A, 66B)

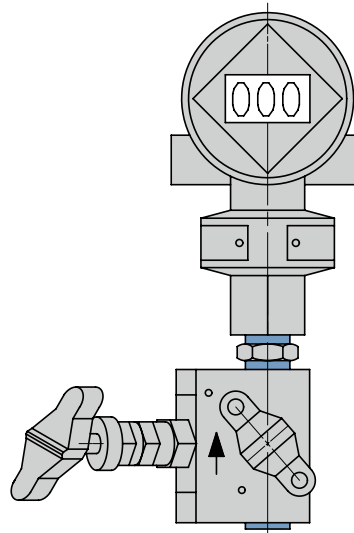

Features

The EagleBurgmann leakage control systems of the SPP6006-A4 range consist of a pressure transmitter which is supplied together with a block and bleed valve as well as an orifice and drain valve.

Circulation in accordance with API 682 4th edition:
Plan 66A, Plan 66B

Advantages

- Compact design
- Easy to integrate in existing piping systems.

Functional description

The SPP6006-A4 leakage control system is used to detect leakage from single seals. In case of a seal failure the SPP6006-A4 is required to monitor excessive leakage. If the seal leakage exceeds a certain value, the bushing / orifice will limit the amount of leakage leaving the seal gland. Consequently the pressure will increase on the upstream side of the inner bushing. The pressure is monitored by means of the transmitter which will provide information about seal performance and seal failure.

Recommended applications

- Refining technology
- Oil and gas industry
- Petrochemical industry
- Chemical industry
- Power plant technology

Designation	SPP6006-A4	SPP6006-A4
Process connections	NPT 1/2"	NPT 1/2"
Pressure range	0 ... 55 bar (0 ... 798 PSI)	0 ... 55 bar (0 ... 798 PSI)
Calibration range ¹⁾	0 ... 16 bar (0 ... 232 PSI)	0 ... 40 bar (0 ... 580 PSI)
Allowable temperature ¹⁾	-29 °C ... +120 °C (-20 °F ... +248 °F)	-29 °C ... +120 °C (-20 °F ... +248 °F)
Wetted parts	316L	316L

Other versions on request.

¹⁾ Design data, permissible working values depend on the actual conditions of service.

LS050 / LSC6 (Plan 75)



Features

The EagleBurgmann leakage control systems of the LS050 range in accordance with API Plan 75 consist of a leakage collection tank with sight-glass and can be equipped with a wide range of measuring instruments.

Circulation in accordance with API 682/ISO 21 049: Plan 75

Advantages

- Leakage collection tank with sight-glass
- Modular system: combination with a wide range of monitoring instruments possible

Functional description

The LS050 leakage control system in accordance with API Plan 75 is used to discharge leakage from liquid-lubricated single seals with downstream safety gas seals where the leakage is liquid under atmospheric conditions.

Standards and approvals

- PED 97/23 EC (Design and production in accordance with EU Pressure Equipment Directive)
- ASME VIII, Div. 1 (Design, calculation and production)

Recommended applications

- Refining technology
- Oil and gas industry
- Petrochemical industry
- Chemical industry

Designation	LS050/M001-D0	LSC6000-A4
Pressure Equipment Directive	ASME	PED ASME
Volume, vessel (liters)	14	14
Allowable pressure ¹⁾	50 bar (725 PSI)	44 bar (638 PSI)
Allowable temperature ¹⁾	-20 °C ... +120 °C (-4 °F ... +248 °F)	-20 °C ... +120 °C (-4 °F ... +248 °F)
Connection seal leakage	¾" NPT(f)	Flange ¾", 600 lbs
Connection collecting system for condensing leakages	¾" NPT(f)	¾" NPT(f)
Connection fluids collection system	¾" NPT(f)	Flange ¾", 600 lbs
Metal parts	1.4571	316L
Seal	T2, Burasil, Viton®	PTFE, Burasil, Viton®, FKM

Other versions on request.

¹⁾ Design data, permissible working values depend on the actual conditions of service.

SPP6 (Plan 76)

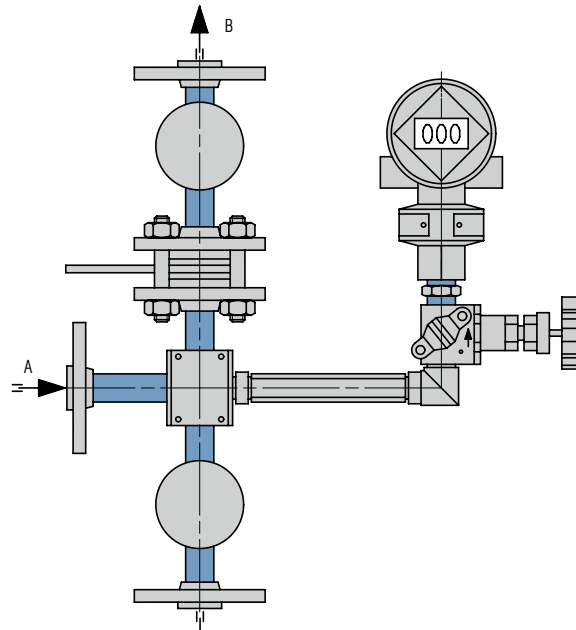
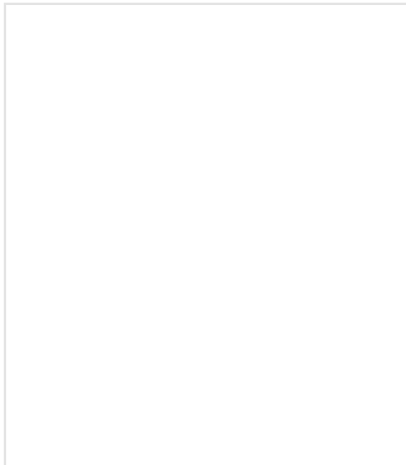

Features

The EagleBurgmann SPP6007 series leakage monitoring system in compliance with API Plan 76 consists of an orifice, valves, and pressure monitoring instruments.

Circulation in accordance with API 682 4th edition: Plan 76

Advantages

- Reliable functionality: System completely preinstalled with orifice, valves and a pressure transmitter (PIT).

Functional description

The SPP6007 leakage monitoring system in compliance with API Plan 76 is used for liquid lubricated single seals with downstream safety gas seal for the removal of leakage, if the leakage is gaseous in environmental conditions.

Recommended applications

- Refining technology
- Oil and gas industry
- Petrochemical industry
- Chemical industry

Item Description

- | Item | Description |
|------|---------------------------------|
| A | From mechanical seal |
| B | To condensate collection system |
| C | Drain |

Designation	SPP6007-A4	SPP6007-A4
Process connections	Flange 3/4", 600 lbs	Flange 3/4", 600 lbs
Pressure range	0 ... 55 bar (0 ... 798 PSI)	0 ... 55 bar (0 ... 798 PSI)
Calibration range ¹⁾	0 ... 16 bar (0 ... 232 PSI)	0 ... 40 bar (0 ... 580 PSI)
Permissible temperature ¹⁾	-29 °C ... +120 °C (-20 °F ... +248 °F)	-29 °C ... +120 °C (-20 °F ... +248 °F)
Parts with product contact	316L	316L

Other versions on request.

¹⁾ Design data, permissible working values depend on the actual conditions of service.

FLC200



Features

The FLC200 is an economical sealing water management solution for reducing operating costs through minimized rates of fresh water and waste water. The FLC200 series is available in 3 basic versions:

- FLC200:** for single mechanical seals with flush
- FLC200Q:** for mechanical seals with quench
- FLC200D:** for double mechanical seals

These 3 basic types are available for 5 different indicated flow ranges and with numerous system components (e. g. mounting supports, stands, hoses, alarm sensors, etc.) and other material combinations.

Circulation in accordance with API 682/ISO 21 049:
Plan 32, Plan 62

Advantages

- Economical supply system
- Optimized sealing water management
- Reduced costs for fresh water and waste water
- Easy operation and cleaning even during operation
- Compact and robust design
- Safe operation even in case of pressure changes
- Quick detection of seal failures

Functional description

The FLC200 flow control unit is designed to enable easy adjustment of the rate of sealing water (flush, quench or buffer water) on rotary machines to the optimum and lowest level of water consumption necessary for the seal's safe operation. Key parameters such as pressure and flow can be permanently monitored for early detection of any malfunctions. The buffer medium is supplied by an external system.

Operating range

- Max. operating pressure: 25 bar (363 PSI)
- Max. operating temperature: 85 °C (185 °F)
- Indicated flow range (pressure drop):
- 0.5 ... 4 l/min. (2 bar at 4 l/min.)
- 1 ... 8 l/min. (2.8 bar at 8 l/min.)
- 4 ... 15 l/min. (2.7 bar at 15 l/min.)
- 8 ... 20 l/min.
- 10 ... 30 l/min. (6 bar at 30 l/min.)

Recommended applications

- Pulp and paper industry

Designation	FLC208-10-00	FLC208Q-00	FLC208D-10-00
Pressure gauge	■		■
Pressure control valve			■
Flow rate (l/min.)	1 ... 8	1 ... 8	1 ... 8
Allowable pressure	10 bar (145 PSI)		10 bar (145 PSI)
Allowable temperature	85 °C (185 °F)	85 °C (185 °F)	85 °C (185 °F)
Accuracy	±5 %	±5 %	±5 %
Housing material	POM	POM	POM
Metal parts	AISI 316 AISI 304	AISI 316 AISI 304	AISI 316 AISI 304
Sight-glass	Grilamid TR 55	Grilamid TR 55	Grilamid TR 55
Seals	FPM	FPM	FPM
Process connections	Hose nozzles for 10 mm hose	Hose nozzles for 10 mm hose	Hose nozzles for 10 mm hose

Other versions on request.

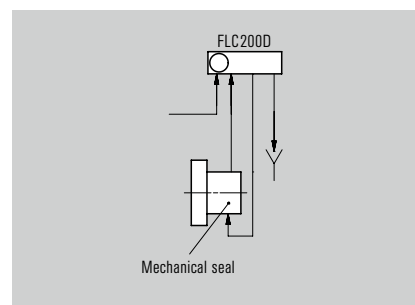
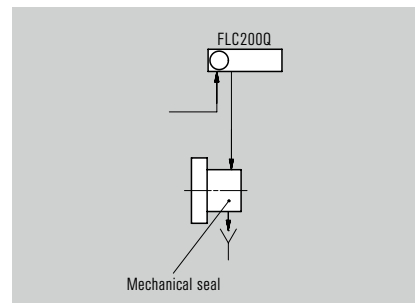
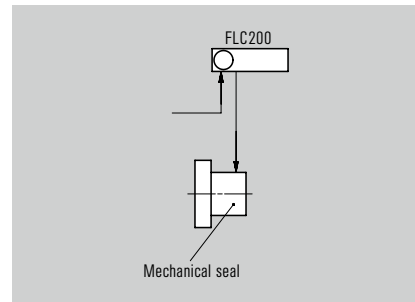

P&ID for
FLC200 for single mechanical seals,
FLC200Q for mechanical seals with quench and
FLC200D for dual mechanical seals.

BestFlow Barrier fluid valve



Features

The EagleBurgmann BestFlow is a temperature-controlled "money-saving valve" for double seals on which the barrier water connection extends directly into the seal chamber, e.g. Cartex-DN.

Advantages

- Reduced, minimum barrier water consumption depending on the seal temperature
- Easy installation and use: no additional connection lines needed
- Venting in horizontal and vertical mounting position
- Long-term assurance of the functionality of the expansion element thanks to its physical and chemical properties
- Rugged, fatigue-free moving parts
- No temperature peaks during opening and closing of the valve thanks to the thermosensitive expansion element
- No power supply required (Ex-protection)
- Pressure-balanced component; pressure fluctuations have no effect on the BestFlow; controlled solely via temperature

Functional description

EagleBurgmann BestFlow controls the buffer water flow via a thermosensitive expansion element. If the temperature in the seal increases above the permitted value, the valve will open automatically. More fresh, cool buffer water can then flow into the seal chamber. As soon as the seal or the barrier fluid has cooled down, the valve closes and the flow is stopped. This ensures that an exchange of barrier medium only takes place when cooling of the seal is required. This results in enormous savings in terms of water consumption, without any compromise in terms of operational reliability and safety. Temperature control for double seals, which are operated in the non-flow mode.

Recommended applications

- Pulp and paper industry
- Water and waste water technology
- Chemical industry

Notes

Temperature control for double seals, which are operated in the non-flow mode.

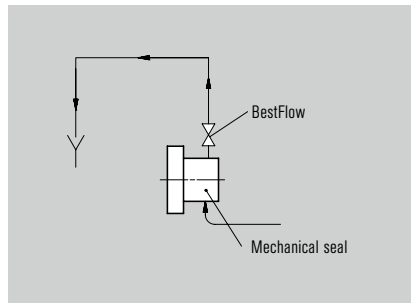

Installation diagram for a BestFlow valve.

Designation	BestFlow-3/8NPT-60	BestFlow-3/8NPT-82
$t_{3 \text{ out}}$	60 °C (140 °F)	82 °C (180 °F)
$p_{2 \text{ max.}}$	16 bar (232 PSI)	16 bar (232 PSI)
$p_2 - p_1 = \Delta p$	min. 2 bar (29 PSI)	min. 2 bar (29 PSI)
Process connections	3/8 NPT	3/8 NPT
Metal parts	1.4571 Brass	1.4571 Brass
Seal	Viton® or EPDM	Viton® or EPDM

Other connection dimensions on request.

SPU Circulation pumps



Features

The SPU circulating pump (shown above: SPU5000) is used for circulating the buffer/barrier fluid in seal supply systems (to increase the cooling capacity). The SPU is suitable for water and other liquids of similarly low viscosity. The SPU is available in 5 basic versions:

SPU1010: without explosion protection

SPU2040: with mechanical seal, with magnetic coupling as an option, ATEX conform

SPU2063: with mechanical seal, with magnetic coupling as an option, ATEX conform

SPU4040: with magnetic coupling, ATEX conform

SPU5000: sealless pump, ATEX conform

Advantages

- SPU4040, SPU5000: sealless pump, hermetically sealed and maintenance-free
- SPU2040, SPU2063 and SPU5000 ATEX conform

Recommended applications

- Petrochemical industry
- Chemical industry
- Oil and gas industry
- Refining technology
- Food and beverage industry
- Pharmaceutical industry

Designation	SPU1010/M001-00	SPU2040/A006-00	SPU2040/A097-D0	SPU2063/A001-00	SPU4040/A002-D0	SPU5000-D0
Type of seal	Sealless	Mechanical seal	Magnetic coupling	Mechanical seal	Magnetic coupling	Magnetic coupling
Max. allowable viscosity (mm ² /s)	10	100	100	100	100	15
Max. working pressure	10 bar (145 PSI)	40 bar (580 PSI)	40 bar (580 PSI)	63 bar (914 PSI)	40 bar (580 PSI)	40 bar (580 PSI)
Max. working temperature	110 °C (230 °F)	150 °C (302 °F)	200 °C (392 °F)	150 °C (302 °F)	150 °C (302 °F)	100 °C (212 °F)
Ingress protection	IP 42	IP 55	IP 65	IP 54	IP 55	IP 65
Explosion protection		Ex e II T3	Ex e II T3	Ex e II T3	Ex II 2G cb TX	Ex d II C T 4
Supply voltage	400 V/50 Hz	400 V/50 Hz	400 V/50 Hz	400 V/50 Hz	400 V/50 Hz	400 V/50 Hz
Power consumption (W)	75	250	250	370	550	120
Weight	2.1 kg (4.6 lb)	8 kg (17.6 lb)	8 kg (17.6 lb)	10 kg (22 lb)	10.3 kg (23 lb)	8 kg (17.6 lb)
Material	1.4301	1.4571/Viton®	1.4571/FEP	1.4571/Viton®	1.4581/Grafit	1.4401/1.4462/1.4571/Viton®/T2/GLIDUR H370

Circulation units with higher performance characteristics or for other media or viscosities on request

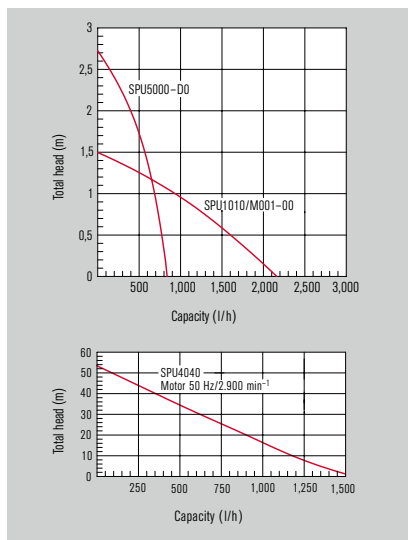

Pumping characteristic for media with viscosity < 15 cSt

Product variants

SPU1010



SPU4040



HPS Screw pumps

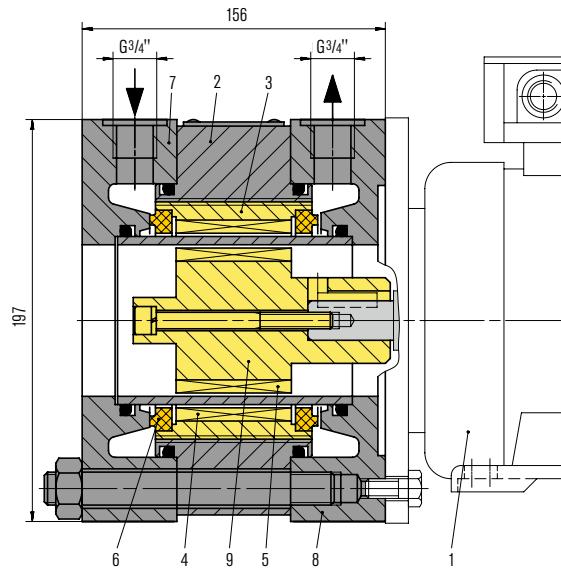

Features

Screw pumps of the HPS range are canned pumps. Their ideal area of application is closed high-pressure circuits within hydraulic process engineering systems. Here the HPS represents a genuine, low-price alternative to the centrifugal pump without stuffing box. HPS pumps are not self-priming, so the pump circuit must be well vented.

HPS4100: screw pump for a max. permissible operating pressure of 100 bar

HPS4200: screw pump for a max. permissible operating pressure of 200 bar

Advantages

- Canned pump: hermetically sealed and requires by and large no maintenance
- For operating pressures of up to max. 100 resp. 200 bar
- Carbon graphite axial and radial bearings: with the pump in operation they are extensively relieved by hydrodynamic centering of the pumping screw and pumping sleeve
- Small overall size

Recommended applications

- Petrochemical industry
- Chemical industry
- Oil and gas industry
- Refining technology
- Food and beverage industry
- Pharmaceutical industry

Item Description

- | Item | Description |
|------|----------------------------------|
| 1 | Three-phase AC motor |
| 2 | Pumping sleeve, stationary |
| 3 | Pumping screw, rotating |
| 4 | Magnet pump rotor |
| 5 | Solenoid actuator |
| 6 | Sliding bearing |
| 7 | Housing cover plate |
| 8 | Housing flange |
| 9 | Shaftelectric soft-start device. |

Notes

For media with higher viscosities than water, it may be necessary to use an electric soft-start device. For screw pumps with a rotational speed of 3,000 min⁻¹ always an electric soft-start device is necessary.

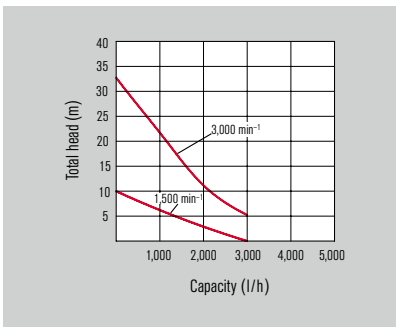

Pumping characteristic with water as medium

Designation	HPS4100/M001-00	HPS4200/M001-00
Max. allowable viscosity (mm ² /s)	<100	<100
Max. working pressure	100 bar (1,450 PSI)	200 bar (2,901 PSI)
Max. working temperature	100 °C (212 °F)	100 °C (212 °F)
Ingress protection	IP 54	IP 55
Speed (min ⁻¹)	1,500	1,500
Type of explosion protection	Ex e	Ex de
Supply voltage	400 V/50 Hz	400 V/50 Hz
Power consumption (W)	550	1,100

Screw pumps with a rotational speed of 3,000 min⁻¹ and other versions on request.

ZY Cyclone separators

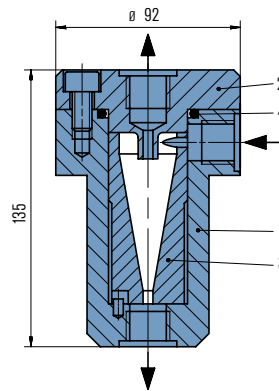

ZY61

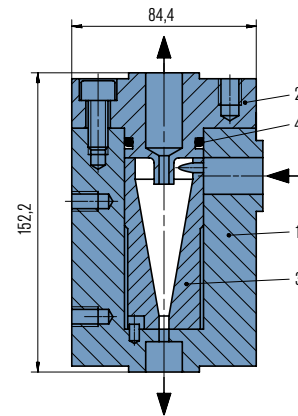

ZY61 in block-type design with integrated flange

Features

The ZY range (shown above: ZY62) is available in 3 basic versions:

ZY61: cyclone separator with replaceable insert made of elastomer or ceramic

ZY62: cast version of the cyclone separator

ZY203: cyclone separator for high flow rates and high pressures

Circulation in accordance with API 682/ISO 21 049: Plan 31, Plan 41

Advantages

- Dirt is automatically conveyed to the suction nozzle of the pump: maintenance-free mode of operation for guaranteed reliability
- High filtration efficiency
- Wide range of products for the optimum solution for every application
- ZY203: for operating pressures of up to 200 bar
- ZY61, ZY203 optional in block-type design with integrated flange connections: low space requirements because of compact design

Functional description

Cyclone separators of the ZY range are used to clean mainly aqueous liquids containing dirt and solids (e.g. in circulation systems of sewage, sludge or pipeline pumps). The best possible filtration efficiency is achieved when the specific weight of the solids is much higher than that of the carrier liquid, and when the differential pressure is as large as possible within the permissible pressure range (min. 1.7 bar in accordance with API 682). The viscosity of the medium is also a factor that needs to be taken into account.

Item Description

Item	Description
1	Housing
2	Cover
3	Insert
4	O-Ring

Recommended applications

- Water and waste water technology
- Petrochemical industry
- Chemical industry
- Oil and gas industry
- Refining technology

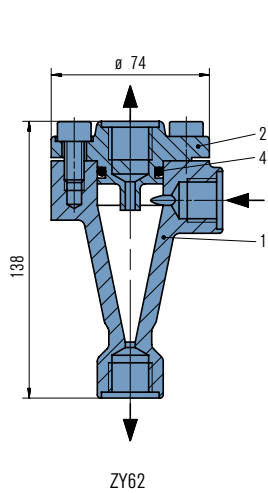

ZY62

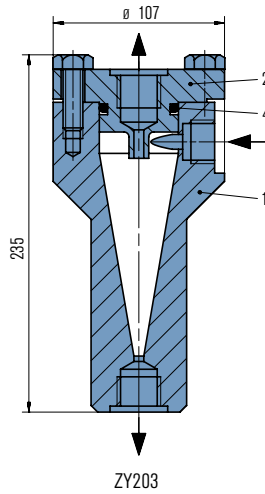

ZY203

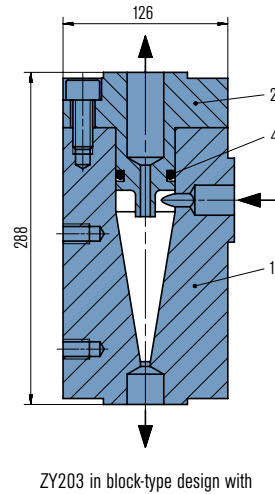

ZY203 in block-type design with integrated flange

Product variant

ZY203 with flange connections

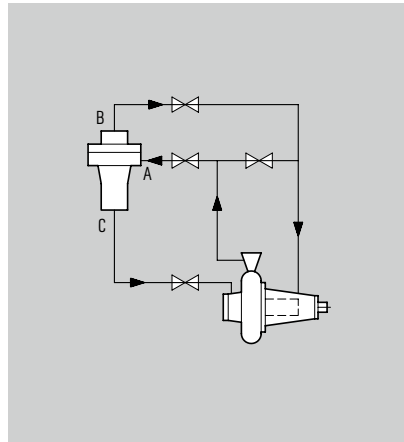

Operating and installation diagram for a cyclone separator.

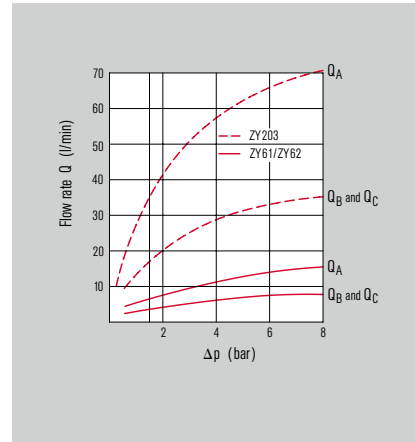

Flow rates for water as medium.

The cyclone separator must always be installed in the vertical position. The pressure at the outlets (C) and (B) must be lower than at the inlet (A). Cleaned liquid is conveyed to the top (B) and the separated dirt to the suction port of the pump.

Designation	Insert	Allowable pressure ¹⁾	Allowable temperature ¹⁾	Process connections	Connection size	Housing, cover	O-Ring
ZY61	Ceramic	64 bar (928 PSI)	125 °C (257 °F)	G, R, NPT, Flange	1/2"	1.4571	Viton®
ZY61	Elastomer	64 bar (928 PSI)	60 °C (140 °F)	G, R, NPT, Flange	1/2"	1.4571	Viton®
ZY61 in block-type design	Ceramic	42 bar (609 PSI)	93 °C (199 °C)	Flange	1/2", 3/4"	1.4462	Viton®
ZY62		64 bar (928 PSI)	125 °C (257 °F)	G, R, NPT, Flange	1/2", 3/4"	1.4408	Viton®
ZY203		200 bar (2,901 PSI)	125 °C (257 °F)	G, R, NPT, Flange	3/4", 1"	1.4571	Viton®
ZY203 in block-type design		233 bar (3,379 PSI)	50 °C (122 °F)	Flange	3/4"	1.4404	Viton®

Other versions on request.

¹⁾ Max. permissible working values depend on version.

MAF2001 Magnetic filter

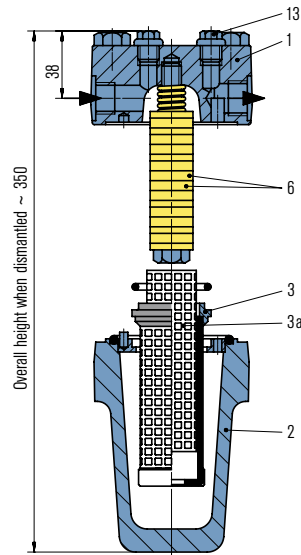

Features

1) Magnetic filters of the MAF2001 range are inline filters for installation inside pipelines. The combination of magnetic rod and filter element guarantees a high level of efficiency. Magnetic filters are used in seal supply systems and any other such systems in which a liquid has to be cleaned of magnetic and non-magnetic impurities up to a certain size.

Advantages

- Combination device: magnetic filter and filter element
- Internal mesh to protect the filter element for reverse currents
- Venting screws in the filter inlet and outlet can be used as connections for maintenance or differential pressure indicator
- Housing can be dismantled: simple maintenance and cleaning
- Two types of contamination indicator are available as accessories: visual monitoring and/or in combination with an electric contact
- All pressure-loaded parts are forged components

Functional description

The magnetic rod is positioned in the filter in such a way that it catches magnetic particles flowing past in the medium on all sides. Partial coarse filtration is provided by the incorporated filter element.

Recommended applications

- Petrochemical industry
- Chemical industry
- Power plant technology
- Refining technology
- Oil and gas industry

Item Description

1	Filter cover
2	Filter barrel
3	Element insert
3a	Internal mesh
6	Ring magnet
13	Venting screw

Designation	Process connections	Allowable pressure	Allowable temperature	Filter grade	Weight (approx.)	Housing, filter head	Filter insert, filter element ²⁾	O-Ring	Gasket
MAF2001/G1/2-00	G 1/2"	63 bar (913 PSI)	150 °C (302 °F)	50 µm	7.8 kg (17.2 lb)	1.4571	1.4301	Viton®	T2
MAF2001/G3/4-00	G 3/4"	63 bar (913 PSI)	150 °C (302 °F)	50 µm	7.8 kg (17.2 lb)	1.4571	1.4301	Viton®	T2
MAF2001/G1-00	G 1"	63 bar (913 PSI)	150 °C (302 °F)	50 µm	7.8 kg (17.2 lb)	1.4571	1.4301	Viton®	T2
MAF2001/NPT1/2"-00	1/2 NPT	63 bar (913 PSI)	150 °C (302 °F)	50 µm	7.8 kg (17.2 lb)	1.4571	1.4301	Viton®	T2
MAF2001/NPT3/4"-00	3/4 NPT	63 bar (913 PSI)	150 °C (302 °F)	50 µm	7.8 kg (17.2 lb)	1.4571	1.4301	Viton®	T2
MAF2001/NPT1"-00	1 NPT	63 bar (913 PSI)	150 °C (302 °F)	50 µm	7.8 kg (17.2 lb)	1.4571	1.4301	Viton®	T2

¹⁾ Higher values on request
²⁾ Other materials on request

MAF203 Magnetic filter



Features

Magnetic filters of the MAF203 range are inline filters for installation inside pipelines. The combination of magnetic rod and filter element guarantees a high level of efficiency. Magnetic filters are used in seal supply systems and any other such systems in which a liquid has to be cleaned of magnetic and non-magnetic impurities up to a certain size.

Advantages

- For operating pressures of up to 200 bar
- Combination device: magnetic filter and filter element in one
- Internal mesh to protect the filter element for reverse currents
- Housing can be dismantled: simple maintenance and cleaning
- Magnetic rod is of short overall height when dismantled: low space requirements for maintenance work

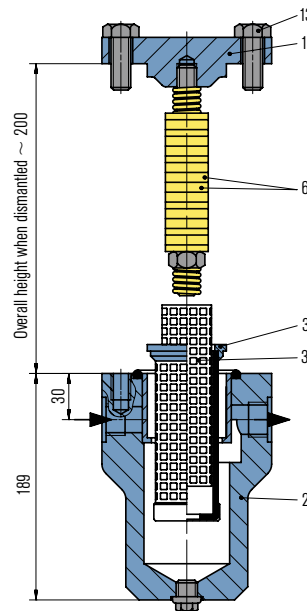

Functional description

The magnetic rod is positioned in the filter in such a way that it catches magnetic particles flowing past in the water on all sides. Partial coarse filtration is provided by the incorporated filter element.

Recommended applications

- Petrochemical industry
- Chemical industry
- Power plant technology
- Refining technology
- Oil and gas industry

Item Description

Item	Description
1	Cover
2	Filter Cover
3	Sleeve
3a	Internal mesh
6	Ring magnet
13	Hex screw

Designation	Process connections	Allowable pressure	Allowable temperature	Filter grade	Weight (approx.)	Housing, cover	Filter element ¹⁾	O-Ring	Gasket
MAF203/G1/2-00	G 1/2"	200 bar (2,900 PSI)	150 °C (302 °F)	50 µm	10.5 kg (23 lb)	1.4571	1.4301	Viton®	T2
MAF203/G3/4-00	G 3/4"	200 bar (2,900 PSI)	150 °C (302 °F)	50 µm	10.5 kg (23 lb)	1.4571	1.4301	Viton®	T2
MAF203/G1-00	G 1"	200 bar (2,900 PSI)	150 °C (302 °F)	50 µm	10.5 kg (23 lb)	1.4571	1.4301	Viton®	T2
MAF203/1/2NPT-00	1/2 NPT	200 bar (2,900 PSI)	150 °C (302 °F)	50 µm	10.5 kg (23 lb)	1.4571	1.4301	Viton®	T2
MAF203/3/4NPT-00	3/4 NPT	200 bar (2,900 PSI)	150 °C (302 °F)	50 µm	10.5 kg (23 lb)	1.4571	1.4301	Viton®	T2
MAF203/1NPT-00	1 NPT	200 bar (2,900 PSI)	150 °C (302 °F)	50 µm	10.5 kg (23 lb)	1.4571	1.4301	Viton®	T2

¹⁾ Other materials on request

MAA Magnetic separators

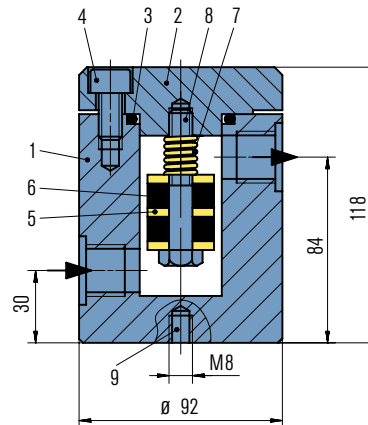

Features

Magnetic separators of the MAA range consist of a pressure casing with integrated magnetic rod. Magnetic separators are used in seal supply systems and any other such systems in which a liquid has to be cleaned of magnetic impurities.

Advantages

- For operating pressures of up to 150 bar
- Housing can be dismantled: simple maintenance and cleaning
- Reliable and rugged technology

Functional description

The magnetic rod is positioned in the casing in such a way that it catches magnetic particles flowing past in the medium on all sides.

Recommended applications

- Chemical industry
- Petrochemical industry
- Power plant technology
- Refining technology
- Oil and gas industry

Notes

Cleaning:

The magnetic rod can be removed for cleaning with the casing fitted by opening the cover (with the line depressurized!). Maintenance intervals depend on the degree of soiling. We recommend checking and if necessary cleaning the magnetic rod several hours after using for the first time and each time after flushing the pipes because experience indicates that much of the dirt is flushed out of the pipes at this time.

Item Description

1, 2	Casing and cover: 1.4571
3	O-Ring: E
4, 8	Screws: A4 – 70 stainless steel
5	Washers: T2
6	Ring magnets: corrosion-resistant
7	Spring: 1.4301
9	Fixing hole

Designation	Process connections	Allowable pressure	Allowable temperature	Volume (liters)	Weight (approx.)	Cover. housing	Spring	O-Ring	Gasket
MAA2120/G1/2-00	G 1/2"	120 bar (1,740 PSI)	160 °C (320 °F)	0.08	5.5 kg (12.2 lb)	1.4571	1.4301	EPDM	T2
MAA2120/1/2NPT-00	1/2 NPT	120 bar (1,740 PSI)	160 °C (320 °F)	0.08	5.6 kg (12.3 lb)	1.4571	1.4301	EPDM	T2
MAA2140/1/2NPT-00	1/2 NPT	140 bar (2,031 PSI)	160 °C (320 °F)	0.08	5.6 kg (12.3 lb)	1.4571	1.4301	EPDM	T2
MAA2150/1/2NPT-00	1/2 NPT	150 bar (2,176 PSI)	150 °C (302 °F)	0.08	5.6 kg (12.3 lb)	1.4571	1.4301	EPDM	T2
MAA2010/FL1/2/150/A001-D1	Flange 1/2"	10 bar (145 PSI)	100 °C (212 °F)	0.08	7 kg (15.4 lb)	1.4571	1.4301	EPDM	FFKM

Other versions on request.

SP23 Flow meter

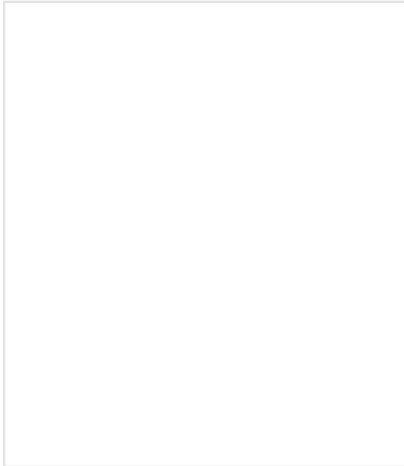

Features

Flow meters of the SP23 range are used for checking the amount of fluid used to refill the barrier fluid circuit in closed systems (e. g. SPN1000/3000). The indicated volume equals the amount lost from the circuit through leakage.

Advantages

- For operating pressures of up to 40 bar or 100 bar as standard
- Local indicator with MIN or MAX contacts
- Available with integrated needle valve
- Parts in contact with the medium are made of 1.4571: excellent media resistance for aggressive liquids
- Wide range of applications throughout the processing industry

Recommended applications

- Process industry

Designation	SP23-26	SP23-41	SP23-42	SP23-46
Measuring range				
0.1 ... 1 l/h ¹⁾		■	■	
0.4 ... 4 l/h ¹⁾	■			■
Proximity contact acc. to NAMUR				
MAX flow	■	■	■	■
Hazardous duty approval				
ATEX Ex ia	■	■	■	■
Control valve				
Needle valve	■	■		
Allowable pressure				
40 bar (580 PSI)	■	■		
100 bar (1,450 PSI)			■	■
Allowable temperature (medium)				
150 °C (302 °F)	■	■	■	■
Material				
Wetted parts	1.4571	1.4571	1.4571	1.4571

Other versions on request.

¹⁾ With water as barrier fluid; other media on request

SP23 Pressure gauge



Features

Bourdon pressure gauges of the SP23 range are used for visual monitoring of the operating pressure.

Advantages

- Analog pressure gauge: indicator range up to 16 bar
- Available in sizes NG63 and NG100
- Parts in contact with the medium are made of 1.4571: excellent media resistance for aggressive liquids
- Wide range of applications throughout the processing industry

Recommended applications

- Process industry

Product variant

Version with pressure gauge shut-off valve already fitted.

Designation	SP23-092	SP23-094	SP23-095	SP23-097
Pressure range				
0 ... 6 bar				■
0 ... 16 bar	■	■	■	
Size				
NG63	■	■		■
NG100			■	
Pressure gauge-Shut-off valve				
Without	■			■
With		■	■	
Proximity contact acc. to NAMUR				
MIN pressure			■	
Hazardous duty approval				
ATEX Ex ia			■	
Material				
Wetted parts	1.4571	1.4571	1.4571	1.4571

Please enquire about other measurement ranges, pressure gauges with contacts resp. with already fitted shut-off valves.

SP23 Temperature gauge



Features

The bi-metallic thermometers of the SP23 range are used for visual monitoring of the operating temperature.

Advantages

- Analog temperature gauge: indicator range up to 120 °C
- Available in size NG63
- Parts in contact with the medium are made of 1.4571: excellent media resistance for aggressive liquids
- Wide range of applications throughout the processing industry

Recommended applications

- Process industry

Designation	SP23-093	SP23-153-00
Temperature range		
0 °C... +120 °C	■	
0 °C... +200 °C		■
Size		
NG63	■	
NG100		■
Proximity contact acc. to NAMUR		
MIN temperature		■
Hazardous duty approval		
ATEX Ex ia		■
Material		
Wetted parts	1.4571	1.4571

Please inquire about other measurement ranges and about thermometers with contacts.

SPI Measuring unit



Features

The measuring unit of the SPI range is used for visual monitoring of the operating temperature and the operating pressure. The measuring unit consists of a pressure gauge (NG100) with a gauge shut-off valve in accordance with DIN 16270, a bi-metallic thermometer with protective sleeve, and a connector. The SPI is suitable for deployment with the TS2000, TS4000, TS5000 and DRU2063.

Advantages

- Pressure range up to 100 bar
- Temperature range up to 200 °C
- Pre-assembled measuring unit with pressure gauge shut-off valve for measuring pressure and temperature
- Parts in contact with the medium are made of 1.4571: excellent media resistance for aggressive liquids
- Wide range of applications throughout the processing industry

Recommended applications

- Process industry

Designation	SPI2000-00	SPI2000/A003	SPI2000/A012	SPI2000/A013	SPI2000/A049	SPI2063-00	SPI2100/A002
Pressure range							
0 ... 40 bar	■	■	■	■	■		
0 ... 100 bar						■	■
Temperature range							
0 °C ... +120 °C		■	■	■	■	■	■
0 °C ... +200 °C	■	■		■	■	■	■
Proximity switch acc. to NAMUR							
MIN pressure		■	■		■		■
MAX pressure		■	■		■		■
MIN temperature		■	■		■		■
MAX temperature		■	■	■	■		■
Hazardous duty approval							
ATEX Ex ia		■	■	■	■		■
Material/weight							
Wetted parts	1.4571	1.4571	1.4571	1.4571	1.4571	1.4571	1.4571
Net weight (approx.)	2.9 kg (6.4 lb)	2.9 kg (6.4 lb)	2.9 kg (6.4 lb)	2.9 kg (6.4 lb)	2.9 kg (6.4 lb)	2.9 kg (6.4 lb)	2.9 kg (6.4 lb)

Please enquire about other measurement ranges and about pressure gauges and thermometers with contacts.

SPL Level indicator



Features

The tank-top mounted level indicators of the SPL range are used for continuous measuring, indication and monitoring of fluid levels. The level indicator consists of a vertical pipe with an integrated floating ball and a magnet system. The indicator strip can be positioned through 360° and is fixed to the outside of the vertical pipe.

Advantages

- Simple and reliable technology
- Magnet system: level indicator functions even if there is a power failure, as it requires no auxiliary power
- For temperatures of up to 200 °C
- Installed in the vessel from above

Functional description

The level indicator functions by means of a floater and a magnet system. The movable two-color metal plates on the indicator strip on the outside of the vertical pipe are actuated/turned by the magnet system.

Recommended applications

- Process industry

Product variant

Version with **SPK2000** contact unit for limit measurements

Notes

Please quote the density of the buffer fluid when placing your order.

Technical data SPL2000

Designation	SPL2000-00
Allowable pressure	63 bar (914 PSI)
Allowable temperature	200 °C (392 °F)
Min. density of medium	0.7 g/cm ³
Material/weight	
Wetted Parts	1.4571
Floater	Titan
Net weight (approx.)	5 kg (11 lb)

SPK Contact unit

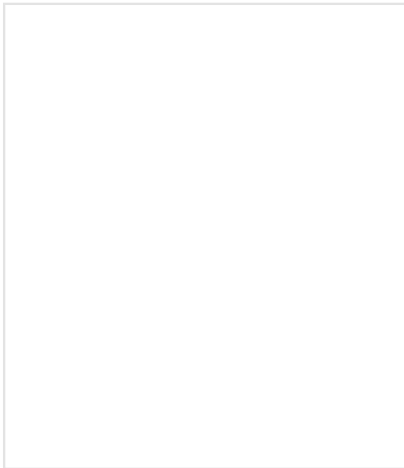

Features	Advantages	Recommended applications
----------	------------	--------------------------

The contact unit of the SPK range is used for fluid level monitoring through zero contact magnetic actuation of a contact. The contact unit consists of one or more magnetic elements which transmit the position of the fluid level or of the pressure booster piston rod to the switches without touching. The switches are reed contacts or inductive contacts in accordance with NAMUR.

- Simple and reliable technology
- Easy to fit
- Wide range of applications throughout the processing industry

• Process industry

Designation	SPK2000/A004	SPK2000/A005	SPK2000/A006	SPK2000/A012	SPK2000/A101	SPK2000/A102	SPK2000/A103
Type							
Reed contact	■	■	■		■	■	■
Proximity contact acc. to NAMUR				■			
Contact position							
MIN level	■	■	■	■	■	■	■
Normal level			■	■			■
MAX level	■		■	■		■	■
Contact function							
Contact breaker	■	■	■				
Flipflop (reversible function)					■	■	■
Ex approval							
ATEX Ex ib				■			
Contact load*)							
Max. 1A/20W/150V	■	■	■				
Max. 0.5A/12W/70V					■	■	■

*) Not in hazardous duty area
With inductive loads, contact protection measures are necessary

SPS Level switch



Features

Level switches of the SPS range are used for monitoring and/or controlling fluid levels in vessels, with alarm and/or control of automatic refill units. The SPS is suitable for deployment with the TS1016/A007, TS2000, TS4000 and TS5000 range.

Advantages

- Monitoring of several levels with a single level switch possible
- Reliable and rugged technology
- For temperatures of up to 250 °C
- Simple installation in the vessel from above
- Wide range of applications throughout the processing industry

Functional description

Level switches of the SPS range function by means of the floating ball principle. Float switches are actuators which are activated when a floating ball is moved by a fluid. The switch consists of a sliding tube with reed contact inserts and a floating ball fitted with a ring magnet on the inside. The floating ball rises when the fluid level in the vessel rises and the magnetic field of the ball actuates a reed contact through the wall of the sliding tube.

Recommended applications

- Process industry

Designation	SPS2000-00	SPS2000/A002	SPS2000/A103	SPS2000/A201	SPS2000/A202	SPS2000/A123	SPS2000/A800	SPS2100/A101	SPS2100/A002
Type									
Float switch with 1 reed contact	■			■				■	
Float switch with 2 reed contacts		■			■				■
Float switch with 3 reed contacts			■						
Ultrasonic switch						■			
Float measuring transducer							■		
Switching points									
MIN level	■	■	■	■	■	■		■	■
MIN/MIN level			■						
MAX level		■	■		■				■
Contact/signal function									
Change over switch	■	■		■	■				
Breaker			■					■	■
Norm. 16 mA, Alarm 8mA						■			
4 – 20 mA							■		
Malfunction									
3.6 oder 21 mA						■			
Harzardous duty approval									
Zone 1 (Ex ib IIC T4)								■	
Zone 1 (Ex d(e) IIC T4-T6)				■	■				
Zone 0 (Ex c ia IIC T3-T6)	■	■	■			■	■		
Ex – certificate									
Certificate acc. ATEX	■	■	■	■	■	■	■	■	
Allowable pressure (medium)									
30 bar (435 PSI), test pressure 40 bar (580 PSI)	■	■					■		
40 bar (580 PSI), test pressure 52 bar (754 PSI)				■	■				
40 bar (580 PSI), test pressure 60 bar (870 PSI)			■						
100 bar (1450 PSI), test pressure 130 bar (1,885 PSI)						■		■	■
Allowable temperature (medium)									
120 °C (248 °F)				■	■			■	■
150 °C (302 °F)						■			
180 °C (356 °F)	■	■	■						
250 °C (482 °F)							■		
Min. density of medium									
0.7 g/cm³	■	■	■	■	■		■		■
0.4 g/cm³						■		■	■
Material/weight									
Wetted parts	1.4571	1.4571	1.4571	1.4571	1.4571	1.4571	1.4571	1.4571	1.4571
Weight (approx.)	1.7 kg (3.75 lb)	1.7 kg (3.75 lb)	1.7 kg (3.75 lb)	1.7 kg (3.75 lb)	1.7 kg (3.75 lb)	1.7 kg (3.75 lb)	1.7 kg (3.75 lb)	1.7 kg (3.75 lb)	1.7 kg (3.75 lb)

Other versions on request.

GSS Gas supply system



Features

Gas supply systems of the GSS range are specially designed for contact-free operated, gas-lubricated mechanical seals. The gas supplied from the supply network (e. g. air or nitrogen) is regulated/monitored by the GSS in accordance with the requirements of the seals being supplied. The GSS systems are equipped with alarm and/or switch-off points depending on specific safety requirements. Centralized monitoring of the measurement values is also possible on request.

Circulation in accordance with API 682/ISO 21 049: Plan 72, Plan 74

Advantages

- Available with a wide range of different instruments
- Safe operation thanks to incorporated pressure regulator with integrated filter
- System mounted on a plate or in housing
- Three variants of the housing version available: painted steel, stainless steel, glass fabric
- Easy wall or rack mounting
- For operating pressures of up to 16 bar

Functional description

Buffered, gas-lubricated mechanical seals may only be used in conjunction with adequately pressurized gas (e. g. from a closed circular nitrogen pipeline provided by the operator). For Plan 74 systems the barrier gas pressure level p_3 must always be higher than the pressure level p_1 of the sealed product, whatever the operational state of the machine. The minimum pressure overlay level (Δp) is specified for the individual seal types.

Main GSS functions:

- Filtering of the buffer and flushing gas
- Pressure monitoring and regulation
- Flow monitoring

Typical tasks for the GSS:

- Buffer/barrier gas supply for double seals
- Gas flushing for single seals
- Gas supply for tandem seals

Product variant

GSS4016/A100 system mounted on a plate

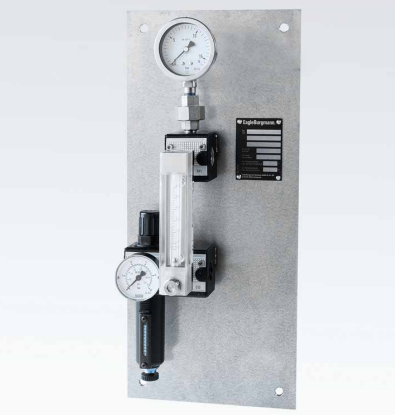

Recommended applications

- Chemical industry
- Petrochemical industry
- Oil and gas industry
- Refining technology
- Pharmaceutical industry
- Food and beverage industry

Note

To assure a sufficient supply of the mechanical seal, pressure at entry of the supply system must be min. 2 bar (29 PSI) above max. barrier pressure always.

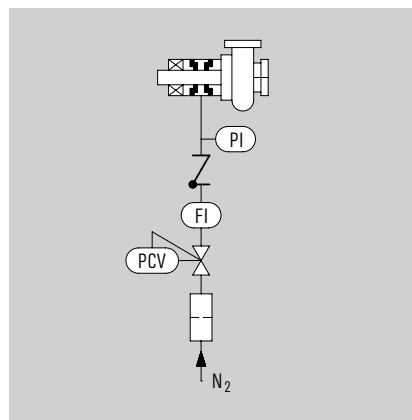

Operating and installation diagram for a GSS system.

GSS4016/A1... range (system mounted on a plate)

Designation	GSS4016/ A100	GSS4016/ A110	GSS4016/ A101	GSS4016/ A111	GSS4016/ A102	GSS4016/ A112	GSS4016/ A103	GSS4016/ A113
Pressure gauge	PI	PI	PIA L	PIA L	PI	PI	PIA L	PIA L
Flow for small measuring range	FI	FI	FI	FI	FI	FI	FI	FI
Flow for large measuring range	FI	FI	FI	FI	FIA H	FIA H	FIA H	FIA H

GSS4016/A2... range (system in housing)

Designation	GSS4016/ A200	GSS4016/ A210	GSS4016/ A201	GSS4016/ A211	GSS4016/ A202	GSS4016/ A212	GSS4016/ A203	GSS4016/ A213
Pressure gauge	PI	PI	PIA L	PIA L	PI	PI	PIA L	PIA L
Flow for small measuring range	FI	FI	FI	FI	FI	FI	FI	FI
Flow for large measuring range	FI	FI	FI	FI	FIA H	FIA H	FIA H	FIA H

GSS4016/A3... range (system in stainless steel, in housing)

Designation	GSS4016/ A300	GSS4016/ A310	GSS4016/ A301	GSS4016/ A311	GSS4016/ A302	GSS4016/ A312	GSS4016/ A303	GSS4016/ A313
Pressure gauge	PI	PI	PIA L	PIA L	PI	PI	PIA L	PIA L
Flow for small measuring range	FI	FI	FI	FI	FI	FI	FI	FI
Flow for large measuring range	FI	FI	FI	FI	FIA H	FIA H	FIA H	FIA H

GSS4016/A... range (system in housing)

Designation	GSS4016/ A250-D1	GSS4016/ A350-D1
Preferred system for agitator seal type	AGSZ	AGSZ
Pressure gauge	PIA L	PIA L
Flow for small measuring range	FIA L	FIA L
Flow for large measuring range	FIA H	FIA H
Pressure to be sealed	0.5 ... 11 bar (7.5 ... 160 PSI)	0.5 ... 11 bar (7.5 ... 160 PSI)
Barrier pressure mechanical seal	2.5 ... 13 bar (36.5 ... 189 PSI)	2.5 ... 13 bar (36.5 ... 189 PSI)
Design pressure	13 bar (189 PSI) max. 16 bar (232 PSI) at 20 °C (68 °F)	13 bar (189 PSI) max. 16 bar (232 PSI) at 20 °C (68 °F)
Material housing	Steel, lacquered	Stainless steel

GSS6000-A4... range (System acc. to API682 4. edition, mounted on a plate)

Designation	GSS6000 A4M001-DO	GSS6001 A4M001-DO
API Plan	Plan 72	Plan 74
Pressure Equipment Directive	ASME	ASME
Allowable pressure	40 bar (580 PSI)	40 bar (580 PSI)
Allowable temperature	-20 °C ... +50 °C (-4 °F ... +122 °F)	-20 °C ... +50 °C (-4 °F ... +122 °F)
Process connections	Flange 1/2", 600 lbs	Flange 1/2", 600 lbs
Metal parts	316L	316L

Other versions on request.

PI: Pressure gauge
 PIA L: Pressure gauge with MIN contact
 FI: Flow meter
 FIA L: Flow meter with MIN contact
 FIA H: Flow meter with MAX contact



GSS6000



GSS6001

RoTechBooster



Features

- Centrifugal design. High reliability and availability
- High efficiency magnetic coupling: 95 % less eddy currents, reduced power consumption, reduced heat generation
- Extended life. 3 – 4 times greater than current boosters (> 24,000 h)
- Environmentally safe. No leakage to the atmosphere
- Simple set-up, easy to operate, virtually maintenance free
- ATEX Certification on request
- Various model available, depending on systems requirements

Advantages

- The RoTechBooster ensures a reliable and consistent flow of gas, even during fluctuating operating conditions. This ensures that clean dry gas is provided to the dry gas seals, resulting in the reliability you expect
- No rubbing shafts or seals and no sliding parts means less parts to maintain.
- Centrifugal solutions are known to be very reliable and eliminate the pulsation in the gas flow
- No oils required for lubrication
- No limitation for lengths of operating times
- Hybrid ceramic bearings and absence of shaft seals provide reliability and longer maintenance cycles with less contacting parts. The bearings will not require any lubrication, eliminating any concerns with lubrication getting into the gas stream.

Operating range

Pressure: $p = 0 \dots 360 \text{ bar (5,221 PSI)}$
 Temperature: $t = -40 \text{ °C} \dots +200 \text{ °C (-40 °F} \dots +392 \text{ °F)}$
 Motor size: 5.5 kW ... 15 kW
 Diameter: 355 mm ... 560 mm (14" ... 22")

Higher pressure or temperature versions on request.

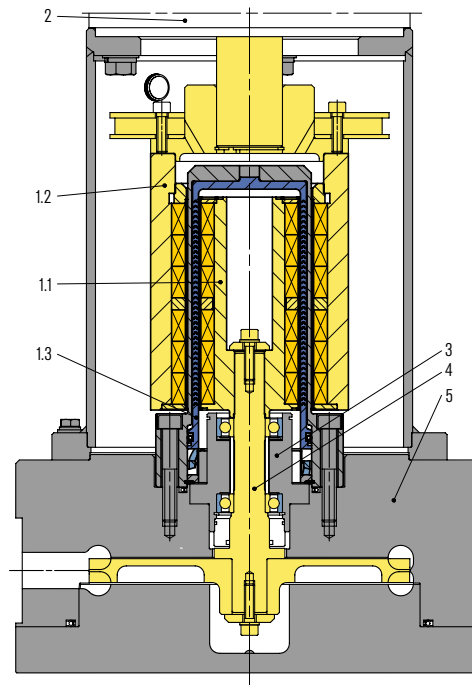

Functional description

A continuous supply of clean and dry gas is essential for the reliability of gas seals. While the compressor is running, process gas can be branched off from a higher pressure stage of the compressor, cleaned, and then used to supply the gas seal.

This effectively protects the gas seal from contaminated process gas. When the compressor operates slowly or stands still, the falling pressure in the compressor makes it no longer possible to circulate an adequate amount of gas through the gas seal. During this extremely critical period for the gas seal, the RoTechBooster is activated and pumps gas from the compressor, through the filter, to the seals.

The supply of clean gas is subsequently secured. Dirt deposits and condensation on the gas seal, caused by contaminated or wet process gas, is prevented. The risk of a leak or damage to the gas seal is minimized.

Item Description

1.1	Inner rotor
1.2	Outer rotor
1.3	Can
2	Motor
3	Bearing cartridge
4	Impeller
5	Pressure housing

Recommended applications

- Chemical industry
- Petrochemical industry
- Refining technology
- Oil and gas industry
- Centrifugal compressors
- Hydrocarbons

Product variants

RoTechBooster 155L/H-120

Impeller type: Single stage, regenerative
 Speed: 1,200 ... 4,200 min⁻¹
 Design pressure:
 Vacuum ... 120 bar (1,740 PSI)
 Design temperature: 200 °C (392 °F)
 Motor size: 5.5 kW ... 15 kW
 Diameter: 355 mm (14")
 Height: 960 mm (38")
 Weight: 215 kg (475 lb)

RoTechBooster 225L/H-120

Impeller type: Single stage, regenerative
 Speed: 1,200 ... 4,200 min⁻¹
 Design pressure:
 Vacuum ... 120 bar (1,740 PSI)
 Design temperature: 200 °C (392 °F)
 Motor size: 5.5 kW ... 15 kW
 Diameter: 410 mm (16")
 Height: 1,120 mm (44")
 Weight: 355 kg (785 lb)

RoTechBooster 275L/H-120

Impeller type: Single stage, regenerative
 Speed: 1,200 ... 4,200 min⁻¹
 Design pressure:
 Vacuum ... 120 bar (1,740 PSI)
 Design temperature: 200 °C (392 °F)
 Motor size: 5.5 kW ... 15 kW
 Diameter: 510 mm (20")
 Height: 1,200 mm (47")
 Weight: 510 kg (1,125 lb)

RoTechBooster 330L/H-120

Impeller type: Single stage, regenerative
 Speed: 1,200 ... 4,200 min⁻¹
 Design pressure:
 Vacuum ... 120 bar (1,740 PSI)
 Design temperature: 200 °C (392 °F)
 Motor size: 5.5 kW ... 15 kW
 Diameter: 560 mm (22")
 Height: 1,245 mm (49")
 Weight: 565 kg (1,245 lb)

Higher pressure models are available upon request.

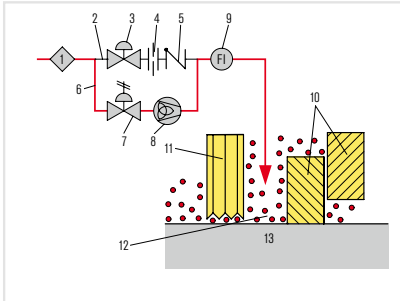

Operating and installation diagram for a RoTechBooster

- 1 Gas filter module
- 2 Seal gas supply module
- 3 PCV
- 4 Orifice
- 5 Check valve
- 6 Seal gas booster module
- 7 PCV
- 8 RoTechBooster
- 9 FI
- 10 DGS
- 11 Process side labyrinth
- 12 Seal gas
- 13 Shaft

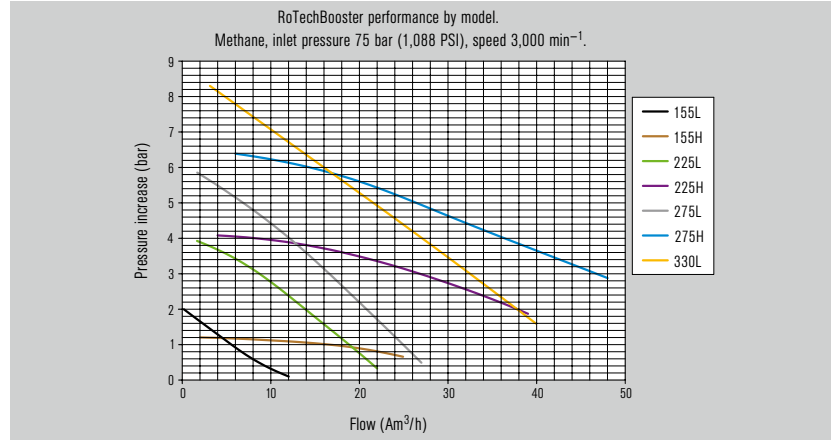

EagleBurgmann gas conditioning system with integrated RoTechBooster.

SMS Seal Management System



Features

The EagleBurgmann SMS is a customizable system based on four modules. It is used to continuously supply and monitor gas-lubricated mechanical seals.

Flushing gas module

Primary seal gas line or buffer gas line:

- Supplying with filtered and dry flushing gas
- Monitoring and regulating the flow rate and/or the (differential) – pressure
- Monitoring the gas filter
- For dual seals, process gas is generally injected in front of the seal as a gas buffer. The actual seal is supplied with nitrogen.

Barrier gas module Secondary seal gas line:

- Supplying with filtered barrier gas (N₂)
- Monitoring and regulating the flow rate and/or the (differential) pressure
- Monitoring the gas filter

Leakage module (Primary) vent line:

- Monitoring of the leakage from the seal and outputting an alarm when the leakage is out of expected range
- Ensuring the leakage is directed to a flare or flare system

Separation gas Separation gas line:

- Supplying and monitoring the oil barrier seal with nitrogen or air
- Monitoring and regulating the flow rate and/or the (differential) pressure

Advantages

- Reliable operation by supplying the seal with filtered and dry buffer gas, seal gas and separation gas.
- Condition of the filters, control valves, instrumentation and nitrogen and process gas sources are checked at all times.
- Constant monitoring for leakage and seal function.
- Individually adaptable to suit operating conditions and safety requirements.
- All current industrial standards, such as API and special operator requirements, can be fulfilled.
- Gas supply system (SMS) available with additional gas conditioning skid.

Functional description

To prevent soiling of the sliding faces, gas is drawn from a higher pressure stage of the compressor, is filtered and injected onto the gas seal as clean “flushing gas”. The leakage from the first gas seal stage is discharged to the primary vent for disposal. To prevent bearing oil from contaminating the gas seal, a further nitrogen or air buffer (“separating gas”) is provided between the bearing side and the gas seal.

Notes

EagleBurgmann SMS systems are also available as complete conditioning skids with individually-adapted components, e.g.:

- Booster
- Cooler
- Heater
- Separator
- Coalescence filter
- Demister

Other equipment and information available upon request.

Recommended applications

- Oil and gas industry
- Refining technology
- Petrochemical industry
- Chemical industry

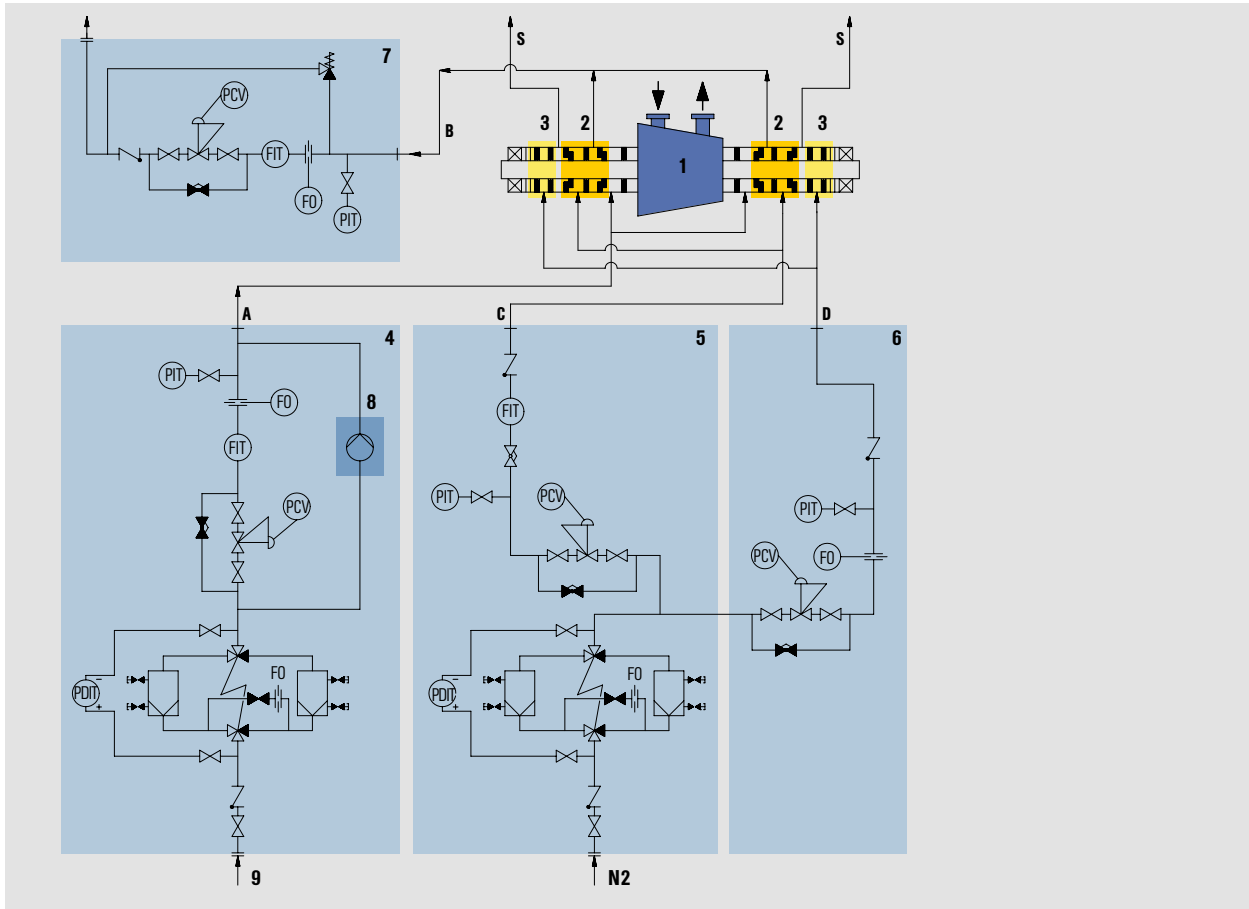

Example of a SMS gas supply system to supply a compressor with 2 tandem seals with intermedia labyrinth.

- | | | | | | | | | | |
|---|------------------|---|-----------------------|---|----------------------------|---|---------------------------|---|-----------------------|
| 1 | 1 Compressor | 4 | Flushing gas module | 7 | Leakage module | A | Primary seal gas supply | S | Secondary vent |
| 2 | Main seal | 5 | Barrier gas module | 8 | RoTechBooster module | B | Primary vent | D | Separation gas supply |
| 3 | Oil barrier seal | 6 | Separating gas module | 9 | Gas conditioning system IN | C | Secondary seal gas supply | | |

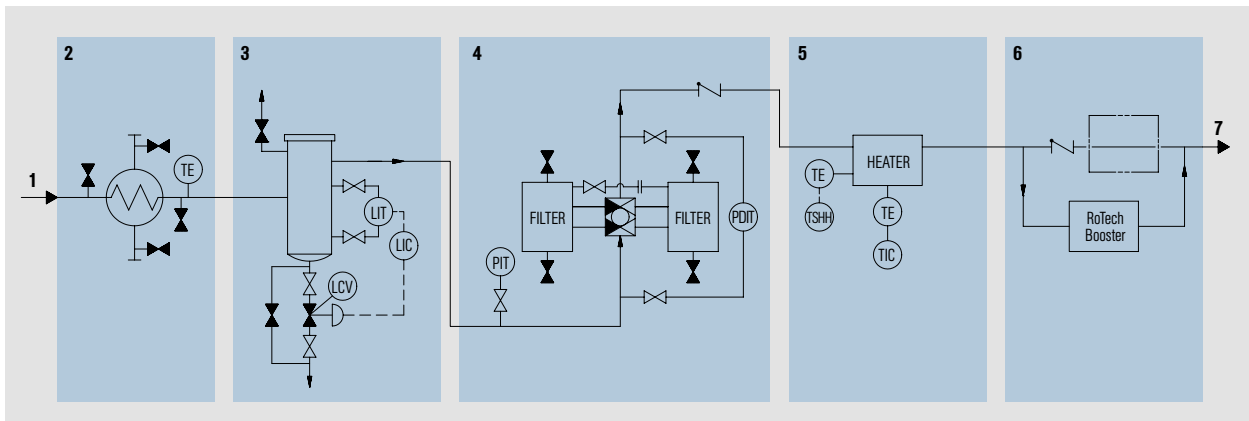

Example of a gas conditioning system (skid).

- | | | | |
|---|-------------|---|----------------------------------|
| 1 | Gas IN | 5 | Heater |
| 2 | Cooler | 6 | RoTechBooster |
| 3 | Separator | 7 | Gas OUT - to flushing gas module |
| 4 | Filter unit | | |

Legend measuring and control points

- | | | | |
|------|---|------|---------------------------------|
| FIT | Flow Indicator and Transmitter | LCV | Level Control Valve |
| FO | Flow Orifice | LIC | Level Indicator Control Valve |
| PCV | Pressure Control Valve | LIT | Level Indicator and Transmitter |
| PDIT | Pressure Differential Indicator and Transmitter | TE | Temperature Transmitter |
| PIT | Pressure Indicator and Transmitter | TIC | Temperature Indicator |
| | | TSHH | Temperature Switch High |

Additional EagleBurgmann product lines

Mechanical seals



Mechanical seals for pumps

EagleBurgmann offers a complete range of liquid and gas-lubricated pump shaft seals including standard and engineered seals in single and multi-seal versions. We also offer a complete range of solutions for all API 682 categories and arrangements. The portfolio includes a broad selection of material and surface technologies such as Diamond-Face coatings.

Cartridge seals

- Easy to install
- Inboard/outboard variants
- For all standard modes of circulation
- O-ring, metal bellows and elastomer bellows seals
- Gas-lubricated versions
- Special versions, e.g. for sterile applications
- Split versions available
- Diameter: 20 ... 110 (250) mm (0.79" ... 4.33 (9.84)")
- Pressure: ... 42 (150) bar (... 609 (2,175) PSI)
- Temperature: -40 °C ... +220 °C (-40 °F ... +428 °F)

Elastomer bellows seals

- Compact design
- Straightforward installation
- Stationary and rotating designs
- Approvals: FDA, WRAS, KTW, ACS, W270, NST
- Diameter: 6 ... 100 mm (0.24" ... 4")
- Pressure: ... 16 bar (... 230 PSI)
- Temperature: ... +140 °C (... +284 °F)

Component seals

- Designed for universal applications
- Versions for high-viscosity media and media containing solids
- Versions for high-performance pumps
- Diameter: ... 400 mm (... 16")
- Pressure: ... 150 bar (... 2,176 PSI)
- Temperature: -50 °C ... +220 °C (-58 °F ... +428 °F)

Metal bellows seals

- For extreme temperature ranges
- For high-viscosity media and media containing solids
- Diameter: 16 ... 100 mm (0.62" ... 4")
- Pressure: vacuum ... 25 bar (... 363 PSI)
- Temperature: -100 °C ... +400 °C (-148 °F ... +752 °F)

Other sizes and engineered seals on request.

Typical applications:

Centrifugal pumps, positive displacements pumps, high-performance pumps, multi-phase and slurry pumps, circulation pumps, hydraulic pumps



Mechanical seals for agitators

Sealing solutions for normal and sterile applications. The design and selection of materials ensure that the seals are rugged enough to deliver excellent cost and engineering performance in all major applications.

Dry-running agitator seals

- Dry-running, contacting seal faces
- For steel and glass lined vessels
- DIN connections or according to customer request
- No seal supply system needed
- FDA-approved face materials
- Diameter: 25 ... 200 mm (1" ... 7.87")
- Pressure: vacuum ... 6 bar (... 87 PSI)
- Temperature: -20 °C ... +250 °C (-4 °F ... +482 °F)

Gas-lubricated agitator seals

- For steel and glass lined vessels
- DIN connections or according to customer request
- FDA-approved face materials
- Non-contacting operation
- Versions for sterile applications
- Diameter: 40 ... 220 mm (1.58" ... 8.7")
- Pressure: vacuum ... 14 bar (... 203 PSI)
- Temperature: -40 °C ... +250 °C (-40 °F ... +482 °F)

Liquid-lubricated agitator seals

- For steel and glass lined vessels
- DIN connections or according to customer request
- FDA-approved face materials
- Designed for all applications
- Diameter: 15 ... 500 mm (0.59" ... 19.69")
- Pressure: vacuum ... 250 bar (... 3,626 PSI)
- Temperature: -80 °C ... +350 °C (-112 °F ... +662 °F)

Typical applications:

Agitators, mixers, dryers, kneaders, reactors, separators, filters



Mechanical seals for compressors

A complete range of products compressors from a single source. Single, double and tandem versions and tandem seals with intermedia labyrinths available.

DGS series

- Standard product series with a proven track record
- Diameter: 29 ... 264 mm (1.14" ... 10.39")
- Pressure: 0 ... 120 bar (0 ... 1,740 PSI)
- Temperature: -20 °C ... +200 °C (-4 °F ... +392 °F)

PDGS high pressure seals

- Elastomer-free, DLC-coated sliding faces
- Diameter: 29 ... 355 mm (1.14" ... 13.98")
- Pressure: 0 ... 450 bar (0 ... 6,526 PSI)
- Temperature: -170 °C ... +230 °C (-274 °F ... +446 °F)

MDGS series for screw compressors

- Seat materials: ductile steel with DM-TiN coating
- Diameter: 40 ... 280 mm (1.57" ... 8.66")
- Pressure: 0 ... 50 bar (0 ... 725 PSI)
- Temperature: -20 °C ... +200 °C (-4 °F ... +392 °F)

TDGS series for steam turbines

- Metal bellows
- Diameter: 40 ... 140 mm (1.5" ... 5.5")
- Pressure: ... 10 bar (... 145 PSI)
- Temperature: -50 °C ... +450 °C (-58 °F ... +842 °F)

Separation seals CSR and CSE

- Very low gas consumption
- Diameter: 29.5 ... 379.5 mm (1.16" ... 14.94")

CobaSeal separation seal

- Insensitive to oil contamination
- Low N₂ consumption
- Face materials: ductile steel with special EagleBurgmann high performance iDLC coating
- Diameter: 29.5 ... 210 mm (1.16" ... 8.27")
- Pressure: 0 ... 15 bar (0 ... 218 PSI)
- Temperature: -20 °C ... +50 °C (-4 °F ... +122 °F)

WRS oil-lubricated seals

- Optimized design due to FEM and computational fluid dynamics
- Diameter: 30 ... 300 mm (1.18" ... 11.81")
- Pressure: ... 50 bar (725 PSI)
- Temperature: -20 °C ... +200 °C (-4 °F ... +392 °F)

Typical applications:

Centrifugal compressors, expanders, turbines, integrally geared compressors, screw compressors, roots compressors, special machines

For detailed information please inquire.

Additional EagleBurgmann product lines

Magnetic couplings

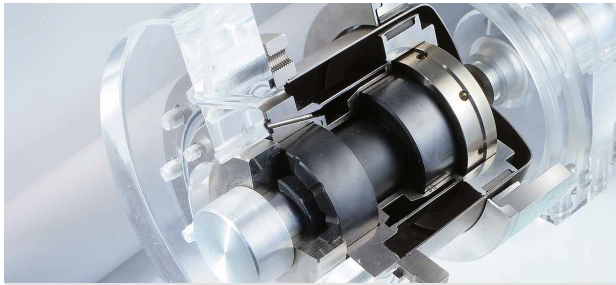

Uncompromising sealing technology for very demanding applications. Hermetically sealed magnetic couplings guarantee leakage-free and maintenance-free pumping and mixing.

The media remains within closed system circulation loops.

MAK series

- Modular design
- Integrated sliding bearing
- Compact dimensions
- Torque transmission ... 462 Nm
- Speed: 3,600 min⁻¹
- Pressure: ... 40 bar (... 580 PSI)
- Temperature: ... +250 °C (... +482 °F)
- Versions for sterile agitator applications
- Optional ceramic or carbon PEEK can

NMB high-efficiency series

- Patented laminated can
- Reduced eddy current losses
- Optional sliding bearing
- Torque transmission: ... 1,879 Nm
- Pressure: ... 45 bar (... 653 PSI)
- Temperature: ... +250 °C (... +482 °F)

LMF1 Bearing for magnetic couplings

- Sliding bearing with ceramic or carbon materials for the shaft end of magnetic coupled pumps
- Suitable for MAK66, MAK685 and NMB HE magnetic couplings and others
- Self lubrication through pump liquid
- Compact dimensions
- Version for increased usage conditions on request

Typical applications:

Centrifugal pumps, positive displacements pumps, vacuum pumps, agitators, mixers, compressors, blowers, special machines

Carbon floating ring seals



Carbon floating ring seals are supplied as maintenance-free compact labyrinth cartridge seals with low leakage. The floating self-adjusting sealing rings provide radial sealing on the shaft with a very small gap. The seal requires no additional lubrication, and it is designed for dry running. Besides pure gas, carbon floating ring seals are also suitable for Atex applications, toxic media, media containing solids, flue gas, dust, powder, vapor, liquid mist, oil mist and penetrating oil.

Espey WD series (split housing)

- Split housing and seal rings allow easy installation
- Pressure: vacuum ... 20 bar (... 290 PSI)
- Shaft diameter: 40 ... 340 mm (1.57" ... 13.39")
- Radial clearance: max. ±5.0 mm (0.2")
- Axial movement: theoretically unlimited
- Temperature: -120 °C ... +800 °C (-184 °F ... +1,472 °F)
- Sliding velocity: 40 ... 150 m/s (131 ... 492 ft/s)

Espey WDK-BHS for bulkhead shaft penetrations

- Split housing and seal rings allow easy installation
- Verified leakage rates
- International type approvals
- Pressure: max. 3 bar (44 PSI)
- Shaft diameter: 40 ... 800 mm (1.57" ... 31.5")
- Radial play: max. 5 mm (0.2")
- Axial movement: theoretically unlimited
- Temperature: max. 225 °C (437 °F)
- Sliding velocity: 40 m/s (131 ft/s)

Special Espey WD series variants

- Seals for top driven agitators and DIN seal chambers
- Blast furnace seals, shaft ... 4,000 mm (... 157.48")
- Seals for mills and centrifuge feed heads

Espey WKA series

- Chamber seal (modular design – can be combined in any order), optional with housing and lid
- Pressure: vacuum ... 250 bar (... 3,626 PSI)
- Shaft diameter: 20 ... 340 mm (0.79" ... 13.39")
- Radial play: max. ± 2.0 mm (0.08")
- Axial movement: theoretically unlimited
- Temperature: -120 °C ... +500 °C (-184 °F ... +932 °F)
- Sliding velocity: 150 ... 240 m/s (492 ... 787 ft/s), depending on type

Espey shaft sleeves

- Metallic or ceramic coating
- One-piece or split design
- Shaft diameter: 45 ... 340 mm (1.77" ... 13.39")
- Temperature: ... +1,000 °C (... +1,832 °F)

Typical applications:

Blowers, compressors, turbines, centrifuges, mills, agitators, dryers, bulkheads, steam turbines, throttle/control valves, gear units, motors

Additional EagleBurgmann product lines

Compression packings



A cost effective and reliable method for sealing pump shafts, valve spindles and rotating shafts in process equipment. Manufactured from a range of material combinations – traditional and innovative – using state-of-the-art production techniques. Supplied in boxed lengths or pre-cut rings. Approvals/certification includes BAM, DVGW, FDA, API, ISO, TA-Luft. Fire-safe, low leakage, low emission and nuclear grades are available with full documentation and certification.

Rotatherm graphite rings

An accepted industry-standard for valves and pumps in high pressure and high temperature service. Manufactured as moulded rings (with and without steel reinforcement) or special seals. Suits all industry applications including the power and nuclear industries. Approvals/certification includes: BAM, DVGW, API, ISO, TA-Luft.

BuraTAL Fugitive emission products

A comprehensive range of low leakage packing sets manufactured in graphite or our unique non-woven materials. All current fugitive emission standards are met with outstanding performance, low friction, ease of installation, and a long service life. Approvals/certification includes: API 622, ISO 15848, TA-Luft.

Burajet Injectable packings

The Burajet Injectable packing system offers a wide range of injectable compounds for pumps, valves, and process equipment. An ideal product for the mining and paper & pulp industries. Approvals/Certification includes: FDA

Buraglas Glass packings

Manufactured from non-ceramic materials and fibres, BuraGlas packings are suitable for sealing of vessels, coal mills, industrial furnaces, oven doors, hatches and covers. Produced in lengths in sizes up to 150 mm section. Approvals/Certification: Hydrolytische Klasse 1; DIN 12111.

Packing cartridges

Packing cartridges combine quick and easy installation with robust simple construction to provide minimum downtime and maximum reliability in critical process applications. Manufactured to individual requirements to fit into DIN/ASME standard equipment e.g. agitators. Cartridges can be supplied with live-loading and additional bellows containment for maximum environmental safety.

Typical applications:

Pumps, agitators, mixers, kneaders, dryers, fans, blowers, filters, refiners, pulpers, mills, valves

Gaskets



Fibre gasket sheets

Burasil-Basic, -Universal and Buratherm N gasket

sheets for service in low to medium pressure and temperature applications for process equipment and pipework in industry and for utility applications like gas and water supply. Approvals/certification includes: DVGW, KTW, HTB, WRAS, WRC, TA-Luft, BAM (Oxygen max. = 120 °C / 130 bar)

PTFE gasket sheets and tapes

Burachem is a highly chemical resistant modified PTFE gasket material range offering varying properties of mechanical strength and chemical resistance depending upon application. Approvals/certification includes: DVGW, KTW, HTB, WRAS, WRC, BAM (Oxygen max. = 120 °C / 130 bar), TA-Luft.

Quick-Seal MultiTex tape is the latest development in the field of expanded PTFE sealing materials for in-place sealing of vessel and pipe flanges.

Graphite seals and tapes

Statotherm Graphite gasket sheets, tapes

Soft, flexible, graphite gasket sheets ideal for pump, valve, and equipment gaskets.

Statotherm R Profile rings for static sealing in high temperature applications, e.g. in heat exchangers, valves or pumps.

Statotherm V and V-Flex cover seals are used as

self-sealing gaskets in high-pressure valves e.g. for power plants at high temperatures. Statotherm V-Flex is supplied by the meter.

Metal gaskets

Approvals/certification include BAM, DVGW, TA-Luft

Spiraltherm spiral wound gaskets. Available to suit all international flange standards and in a wide choice of materials.

Corratherm corrugated gaskets are for heavy duty applications.

Kammprofile serrated gaskets are for applications with high demands for operating safety and tightness.

Buralloy metal jacketed gaskets are produced in a wide variety of different materials (in various combinations), in many styles for heat exchangers, pipe flanges, boilers, and process equipment.

Buralloy ring type joints are available to suit all ASME and DIN flanges from stock. Sizes: 15 ... 900 mm (0.5" ... 36"); manufactured to ASME B16.20 and to API 6A.

Typical applications:

Stationary machine parts, flanges, flange-like joints, bulkheads

For detailed information please inquire.

Additional EagleBurgmann product lines

Expansion joints



Expansion joints are vital components in most industrial plants. They are installed as flexible connections in pipe and duct systems to take up or compensate for thermal expansion, vibration and misalignments. Advancements in processing and generating technologies are being combined with high demands for efficiency. This, along with a clear orientation towards environmental protection, puts high demands on expansion joint designs.

Customized expansion joints made of fabric or metal are the solution of choice.

Fabric expansion joints

- Single and multilayer designs
- Dimensions: according to customer specifications
- Temperature: $-35\text{ °C} \dots +1,000\text{ °C}$ ($-31\text{ °F} \dots + 1,832\text{ °F}$) (higher temperature, on request)
- Pressure: $\pm 0.35\text{ bar}$
- Versions with wiremesh reinforcement
- Versions with high chemical resistance
- Versions with Nekal-tight design
- Fabric expansion joints are available as units, including bolster and steel parts.

Metal expansion joints

- Dimensions: Circular: DN40 and up.
- Rectangular: According to customer specifications
- Temperature: $-198\text{ °C} \dots +1,371\text{ °C}$ ($-324\text{ °F} \dots + 2,500\text{ °F}$)
- Pressure: vacuum ... 172 bar (... 2,500 PSI)
- Materials: stainless steel, Incoloy® Inconel®, Hastelloy®, titanium, special materials
- Single and universal designs
- Metal expansion joints are available with for example tie rods, hinges, gimbals, refractory lining, elbow, pantograph.

Dimensions and pressure range depends on design, material selection, type of expansion joint and duct insulation.

Typical applications:

Air and flue gas ducts, pipelines, sewer systems

Special products



For particular applications, innovative, customized solutions are the only answer. The supplier must have a wealth of in-depth expertise, many years of experience and above all the willingness and ability to translate ideas into solutions that work in practical application.

Contoured diaphragm couplings

For demanding rotating equipment such as turbines and compressors in the oil and gas industries as well as petrochemicals, conventional and nuclear power generation, marine applications and the aerospace industry.

They are lightweight, easy to install and maintain, and demonstrate high reliability in stress analysis. Low bearing load, best dynamic balance repeatability and no fretting or wearing are advantages of the coupling. Uniquely shaped flexible elements in the metal diaphragms located at each end of the spacers attain optimum performance. Additional features:

- Couplings acc. to API 671 / ISO10441 or API 610 / ISO13709
- Multi diaphragms, compensation for large misalignments
- Low (reduced) moment
- Electrically insulated
- Spark resistant materials
- Tuned for rotor dynamics
- Torque overload releasing device
- Torque measuring system

Operating range: Max. torque: 2,700 kNm, max. speed: 100,000 min⁻¹

High-grade metal bellows

for specialized applications in the nuclear power, semi conductor and medical equipment industries, etc.

Dynamic and static sealing elements

for the aerospace industry which meet extremely demanding quality requirements.

Stern tube and marine seals

with various approvals and certifications, for marine outfitters and users.

Rotary kiln sealing systems

as single and double seals in drying, calcination, combustion and pyrolysis applications.

Typical applications:

Engineered solutions designed to meet customer requirements

TotalSealCare Service

TotalSealCare service modules

The modular seal service offered through TotalSealCare is as individual as are the demands of our customers. The range of services spans complete maintenance of all installed seals, through to stock management, as well as engineering, training and electronic data documentation.

Our TotalSealCare services consist of individual modules from which we assemble individualized service packages.

You can benefit from our many years of experience and expertise in all areas of seal technology, and our major store of practical knowledge.



Consulting & engineering

After establishing and analyzing all of the seals in a system, we work out standardization concepts based on the as-is status. The results we are hoping for are to reduce the number of seal types, sizes and materials used, and to improve the key figures of the system. We advise you relating to codes of practice and statutory regulations, and indicate what actions need to be taken.

Maintenance

In the plant or in the service center, qualified fitters and technicians look after all the aspects of seal maintenance: installation, startup, servicing, conversion, overhaul and repair. We record and document functionally relevant data (fault causes, measures for repair, costs). This means it is possible to assess seal operating times and maintenance costs on a continuous basis, thereby defining measures for extending service intervals.

On-site service

Our on-site service includes the components of an overhaul service, conversions and service container. We deploy a service unit directly on your premises: equipped with the basic suite of seals or a stock of seals discussed with you in advance, and staffed by qualified personnel. On-site, our work includes producing the necessary gaskets, ensuring that the documentation is complete and advising our customers on selecting and installing seals. Our range of services is rounded off by complete conversions (e.g. acc. to TA-Luft).

Inventory management

Based on your individual requirements and the applicable quality regulations, we develop a concept for inventory management of complete seals and spare parts. Furthermore, we optimize stocking on site or in the EagleBurgmann service center. In this way, you can reduce your administration overhead and concentrate on your key operations.

Seminars & training

We offer an extensive range of continuing education programs in seal technology. For service and maintenance personnel, skilled staff and engineers from various branches of industry such as refining, chemicals, power generation, foodstuffs, paper and pharmaceuticals. Our range includes group seminars, individual training and seminars specifically tailored to your requirements. At our premises or at a location of your choice.

Technical analysis & support

A team of seal specialists is responsible for rectifying process malfunctions or "bad actors". The latest methods such as thermography or data logging are used for diagnosing positions that are critical for the operation of the system and for working out measures to rectify them. In our research and development centers, we perform realistic tests on test rigs or in original pumps. The objective is to extend the MTBF and to increase system serviceability by individual and constructive solutions.

Service agreements

We offer our customers specific agreements that can be combined from the six service modules. Whether for individual seal systems, critical process elements, specific system areas or an extensive seal service for complete plants: the modular structure of our service makes it possible to satisfy individual requirements. With our tried-and-tested monitoring instrument, SEPRO, we can also record all data relevant for the seals for documentation and evaluation purposes.

Algeria · Angola · **Argentina** · **Australia** · **Austria** · Bahrain · Bangladesh · Belarus · **Belgium** · Botswana · **Brazil** · Bulgaria · Cameroon · **Canada** · Chile · **China** · **Colombia** · Congo · Cyprus · **Czech Republic** · **Denmark** · **Ecuador** · Egypt · Estonia · Finland · **France** · Gabon · **Germany** · Ghana · **Great Britain** · Greece · **Hungary** · **India** · **Indonesia** · Iraq · Ireland · Israel · **Italy** · Ivory Coast · **Japan** · Jordan · Kazakhstan · Kenya · **Korea** · Kuwait · Latvia · Lebanon · Libya · Lithuania · Madagascar · **Malaysia** · Mauritius · **Mexico** · Morocco · Myanmar · Namibia · **Netherlands** · **New Zealand** · Nigeria · **Norway** · Oman · Pakistan · Paraguay · Peru · **Philippines** · **Poland** · Qatar · Romania · **Russia** · **Saudi Arabia** · Serbia · **Singapore** · Slovak Republic · Slovenia · **South Africa** · **Spain** · Sudan · **Sweden** · **Switzerland** · **Taiwan** · **Thailand** · Trinidad and Tobago · Tunisia · **Turkey** · Ukraine · **United Arab Emirates** · Uruguay · **USA** · **Venezuela** · **Vietnam** · Yemen · Zambia · Zimbabwe · www.eagleburgmann.com/world



DMS_SSE/ES/3.000/07/15/0.71 © EagleBurgmann Group, Marketing, Germany

EagleBurgmann is one of the internationally leading companies for industrial sealing technology. Our products are used everywhere where safety and reliability are important: in the oil and gas industry, refining technology, the petrochemical, chemical and pharmaceutical industries, food processing, power, water, mining, pulp & paper, aerospace and many other spheres. Every day, more than 6,000 employees contribute their ideas, solutions and commitment towards ensuring that customers all over the world can rely on our seals. Our modular TotalSealCare service underlines our strong customer orientation and offers tailor-made services for every application.

eagleburgmann.com
info@eagleburgmann.com

EagleBurgmann®
 Rely on excellence