

Compact C Pump



A competitively priced progressing cavity pump, with a compact construction and maximum performance characteristics.

Typical Applications

- Domestic and industrial effluent
- Hydrated lime slurry
- Sludge
- Shear sensitive latex emulsion
- Milk curds, sauces, fruit juices
- Industrial chemicals and detergents
- Starch slurries
- Coating clays, gypsum and silicate
- Paper stocks
- Agricultural slurries

Capacity

- Up to 990 gal/min

Pressure

- Up to 350 psi

Temperature

- 14°F up to 212°F

Features and Benefits

Compact Unit

As the drive forms an integral part of the unit, the pump is ideal for space-saving installations.

Materials of Construction

Available in cast iron or stainless steel, with a choice of rotor and stator materials to suit individual applications e.g. hard chrome plated rotor or natural rubber stator.

High Pressure/Long Haul Pumping

Can offer considerable project cost savings by utilizing small borehole pipework and eliminating the need for series of pumps when pumping over long distances or with high head requirements.

Low Running Speeds

Reduced wear for a longer working pump life which extends the periods between routine maintenance. Think of the savings that could be realized on abrasive applications.

Up to 28 Feet Suction Lift

Deep sumps can be easily pumped without the use of submersible equipment.

Duracoat Coating

Rotors can be supplied with specialized coatings to help extend the life of the rotors through improve wear and corrosion resistance.

Viscous Products and Heavy Solids

The pump can be supplied with a square inlet and conveyor to assist viscous slurries into the pumping element.

Gentle Pumping Action

Minimizes shear and crush damage to the pumped product.

Inspection Cover

Available for applications where rag content is a problem.

Robust Drives

Specially selected drives and gearboxes for longer life. Options include electric motor drive units supplied as overhead v-belt driven, direct-coupled, or variable speed drives with mechanical variable speed or frequency inverter.



Compact C Pump

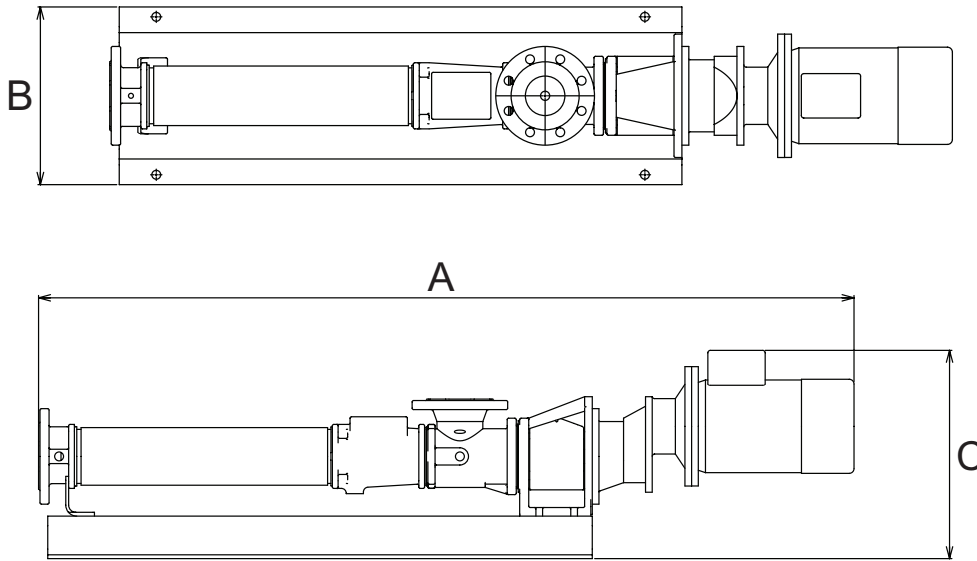

Performance

K Build	
1937	C1CK
990	C1BK
726	C1AK
550	C19K
427	C18K / S18K
347	C17K / S17K
250	C16K / S16K
162	C15K / S15K
96	C14K / S14K
57	C1XK
44	C23K

0 58 87
Differential Pressure - PSI

	Single Stage	Two Stage	Four Stage
1276	C1DA		
924	C1CA	C1CB	
616	C1BA	C1BB	
413	C1AA	C1AB	
314	C19A	C19B	
253	C18A / S18A	C18B	C18D
217	C17A / S17A	C17B	C17D
156	C16A / S16A	C16B	C16D
112	C15A / S15A	C15B	C15D
63	C14A / S14A	C14B	C14D
49	C2XA	C2XB	C1XD
26	C23A	C23B	C13D
15	C22A	C22A	C22D
6	C21B		C21D

0 87 175 350
Differential Pressure - PSI

Dimensions

Model	A	B	C
C1XK	51	12	12
C14K	66	12	19
C15K	70	14	19
C16K	77	14	19
C17K	97	14	24
C18K	104	17	24
C19K	114	17	26
C1AK	120	17	26
C1BK	137	21	21
C1CK	193	31	37
C13D	72	14	19
C2XA	44	12	12
C2XB	52	12	12
C1XD	80	17	19
C14A	57	12	19
C14B	66	12	19
C14D	84	14	19
C15A	60	12	19
C15B	72	14	19
C15D	109	17	24
C16A	64	14	19
C16B	92	17	24
C16D	127	21	19
C17A	81	14	23
C17B	97	14	24
C17D	145	21	29
C18A	87	14	23
C18B	110	17	26
C18D	151	21	21
C19A	96	17	26
C19B	114	17	26

Model	A	B	C
C1AA	99	17	26
C1AB	126	21	29
C1BA	112	21	29
C1BB	171	30	35
C1CA	159	30	35
C1CB	193	31	37
C1DA	171	30	35
C21B	39	12	12
C21D	45	12	12
C22A	39	12	12
C22B	45	12	12
C22D	61	12	12
C23A	43	12	12
C23B	49	12	12
C23K	49	12	12

Square Inlet Units			
Model	A	B	C
S14A	57	12	19
S14K	66	12	19
S15A	60	12	19
S15K	70	14	19
S16A	65	14	19
S16K	77	14	19
S17A	81	14	23
S17K	97	14	24
S18A	87	14	23
S18K	104	17	24

All dimensions are in inches and for guidance only. Flanges to ANSI B16.1, B16.5 and NPT pipe thread.

