

EZstrip™ Cake Pump



The EZstrip Cake Pump is designed with a large auger inlet and screw conveyor. The screw conveyor extends to the compression area to help push the sludge cake into the cavities of the rotor and stator and provide consistent pumping.

Benefits and Features

The range is available in cast iron, with a choice of rotor and stator materials and a variety of hopper sizes.

- Quick and easy to maintain in place
- Reduced maintenance downtime and labour savings
- No need to disconnect suction and discharge pipework, even when removing the screw conveyor
- Detachable feed chamber supplied as standard
- WIMES specification Efficiency 1 motors supplied as standard

Capacity

Up to 215 gal/min (49m³/h)

Pressure

Up to 350 psi (24 bar)

Temperature

14°F up to 212°F (-10°C up to 100°C)

Typical applications

Thickened sludge cake (upto 40% dry solids content), dewatered sludge, sludge blending, including lime powder dosing and lime slurry dosing in conjunction with barrier layer injection.

EZstrip Cake Pump

To minimize the downtime and cost involved when maintaining a progressing cavity pump, the EZstrip Cake Pump can be fully maintained in place, without disconnecting pipework or removing the hopper.

Once the pumping elements have been disconnected, the middle support foot allows the feed chamber and rotor and stator to be turned, to assist removal of these parts. Alternatively, the complete assembly can be lifted out and returned to your workshop or bench for maintenance.

A full drive train including rotor, stator and screw conveyor can be removed in just 8 minutes using standard tools.

Sludge Treatment Applications

- Blending
- Thickening
- Lime Slurry Dosing
- Dewatering
- Lime Powder Dosing
- Barrier Layer Injection
- Digestion

Performance Data

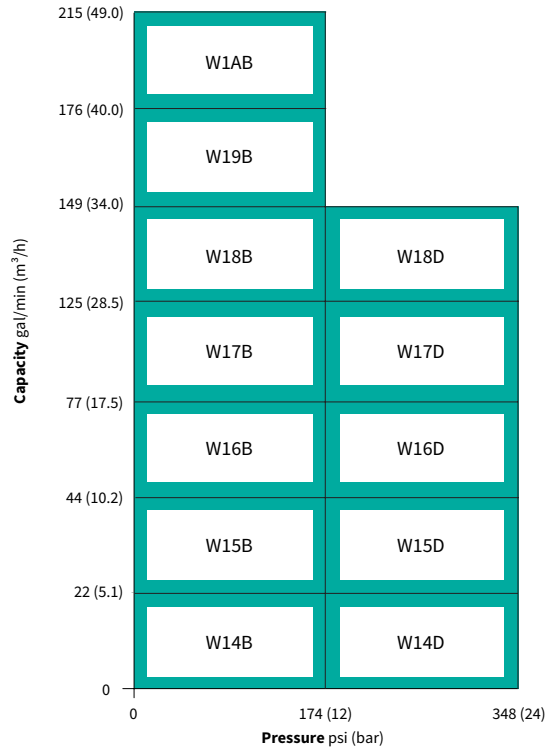

For higher flow rates and pressures, please contact NOV.

Dimensions

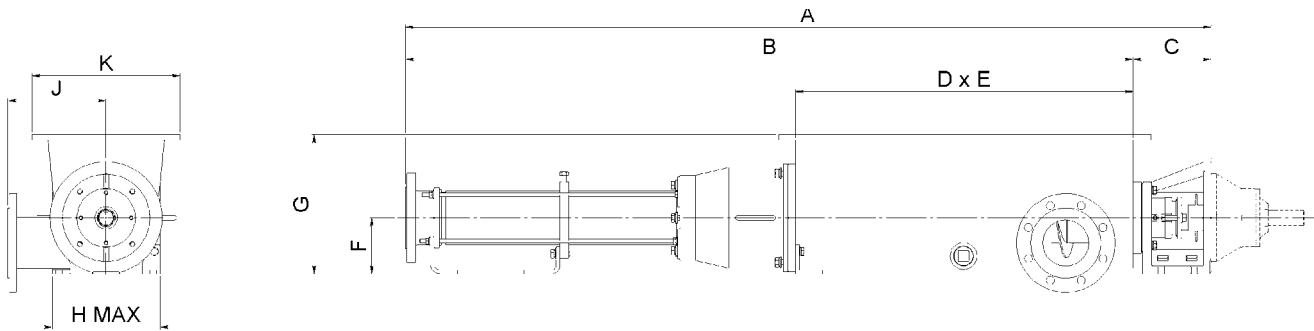

MODEL	A (in/mm)		B (in/mm)		C (in/mm)		D (in/mm)		E (in/mm)		F (in/mm)		G (in/mm)		H (in/mm)		J (in/mm)		K (in/mm)	
W14B	64.4	1636	57.7	1468	6.6	168	29.5	750	9.8	250	4.4	112	11.1	282	8.2	210	10.6	270	11.4	290
W14D	82.0	2084	75.0	1907	6.9	177	29.5	750	9.8	250	4.9	125	11.6	295	8.2	210	10.6	270	11.4	290
W15B	70.7	1797	63.8	1623	6.8	174	29.5	750	9.8	250	4.9	125	12.2	310	9.4	240	12.5	320	11.4	290
W15D	93.9	2386	85.9	2182	8.0	204	29.5	750	9.8	250	5.9	150	13.1	335	9.4	240	12.5	320	11.4	290
W16B	87.2	2216	79.2	2012	8.0	204	39.3	1000	14.1	360	5.9	150	14.7	375	11.4	290	12.5	320	15.7	400
W16D	115.0	2923	105.9	2691	9.1	232	39.3	1000	14.1	360	6.2	160	15.0	382	11.4	290	12.5	320	15.7	400
W17B	94.8	2410	86.6	2202	8.1	208	39.3	1000	14.1	360	6.8	175	16.3	415	13.1	335	12.5	320	15.7	400
W17D	131.9	3352	121.6	3089	10.3	263	39.3	1000	14.1	360	8.8	225	18.3	465	13.1	335	12.5	320	15.7	400
W18B	101.7	2584	92.2	2343	9.4	241	39.3	1000	14.1	360	8.8	225	19.8	505	15.1	385	13.7	350	15.7	400
W18D	139.0	3533	128.6	3268	10.4	265	39.3	1000	14.1	360	8.8	225	19.8	505	15.7	400	13.7	350	15.7	400
W19B	108.9	2768	99.8	2535	9.1	233	39.3	1000	14.1	360	8.8	225	19.8	505	16.9	430	13.7	350	15.7	400
W1AB	122.0	3100	111.5	2834	10.4	266	39.3	1000	14.1	360	9.8	250	21.6	550	18.7	475	13.7	350	15.7	400

* Can be supplied with either fixed speed inverter rated or mechanical variable speed drive.
All dimensions in inches (millimeters) and for guidance only. For full certified drawings, please contact NOV.

